

2I385S

**Intel Bay Trail-D J1900 (Quad Core) CPU,
On Board 2GB DDR3L 1333 MT/s,
2 x LAN, 2 x HDMI, USB**

All-In-One

**Intel Bay Trail-I D1900 (Quad Core 2.0 GHZ) CPU,
2 x Intel GbE LAN, 2 x PCIe mini card slots, 1 x HDMI, 1 x Mini HDMI,
Audio, SATA, USB, Mirco USB, Wide Range DC-IN**

CAUTION

**RISK OF EXPLOSION IF BATTERY IS REPLACED
BY AN INCORRECT TYPE.
DISPOSE OF USED BATTERIES ACCORDING
TO THE INSTRUCTIONS**

Contents

2I385S	
Warning!.....	1
Hardware Notice Guide	2
CHAPTER 1 GENERAL INFORMATION	4
1-1 MAJOR FEATURE.....	5
1-2 SPECIFICATION	6
1-3 INSTALLING THE MINI PCI-E CARD	7
1-4 DIRECTIONS FOR INSTALLING THE MINI CARD	8
1-5 PACKING LIST	9
CHAPTER 2 HARDWARE INSTALLATION	10
2-1 UNPACKING PRECAUTION	10
2-2 UNPACKING CHECKUP	11
2-3 DIMENSION-2I385S	12
2-4 LAYOUT-2I385S-CONNECTOR AND JUMPER	13
2-4-1 LAYOUT-2I385S-CONNECTOR AND JUMPER BOTTOM	14
2-5 DIAGRAM-2I385S	15
2-5-1 BOTTOM SIDE DIAGRAM-2I385S	16
2-6 LIST OF JUMPERS	17
2-7 JUMPER SETTING DESCRIPTION	17
2-8 JSB1: CMOS DATA CLEAR	18
CHAPTER 3 CONNECTION	19
3-1 LIST OF CONNECTORS.....	19
3-2 DC -IN INTERNAL CONNECTOR	20
3-3 CMOS BATTERY CONNECTOR	21
3-4 DC+12V/+5V VOLTGE OUTPUT	22
3-5 VGA WAFER	22
3-6 COM INTERFACE	23
3-7 AUDIO INTERFACE	24
3-8 I ² C BUS INTERFACE	25
3-9 LAN INTERFACE	26
3-10 USB INTERFACE	27
3-11 HDMI INTERFACE	28
3-12 LED	29
3-13 POWER BOTTON CONNECTOR	29
3-14 MINI PCIE SOCKRT	30
3-15 SATA INTERFACE	31
CHAPTER 4 INTRODUCTION OF BIOS	32
4-1 ENTER SETUP	32
4-2 BIOS MENU SCREEN & FUNCTION KEYS	33

4-3 GETTING HELP	34
4-4 MENU BARS	35
4-5 MAIN	35
4-6 ADVANCED	36
4-6-1 BOOT CONFIGURATION	37
4-6-2 PCI EXPRESS CONFIGURATION	37
4-6-2-1 PCI EXPRESS ROOT PORT 1/2/3/4	38
4-6-3 USB CONFIGURATION	38
4-6-4 VIDEO CONFIGURATION	39
4-6-5 THERMAL CONFIGURATION	40
4-6-6 SATA CONFIGURATION	41
4-6-7 ACPI TABLE/FEATURES CONTROL	42
4-7 SECURITY	43
4-8 POWER	44
4-9 BOOT	45
4-9-1 LEGACY	46
4-9-2 BOOT TYPE ORDER	47
4-10 EXIT	48
4-11 DEVICE MANAAGER	49
4-11-1 SIO FINTEK81801U	49
4-11-2 HARDWARE MONITOR	50
CHAPTER 5 DRIVER INSTALLATION	51
5-1 INF INSTALL INTEL BAYTRAIL CHIPSET DRIVER (EXAMPLE FOR WIN8 64BIT)	54
5-2 VGA INSTALL INTEL BAYTRAIL VGA DRIVER (EXAMPLE FOR WIN8 64BIT)	56
5-3 SERIAL IO INSTALL DRIVER BAYTRAIL SERIAL IO DRIVER (FOR WINDOWS 7 ONLY)	58
5-4 XHCI INSTALL INTEL USB 3.0 XHCI DRIVER (FOR WINDOWS 7 ONLY)	60
5-5 HD AUDIO INSTALL HIGH DEFINITION AUDIO DRIVER	62
5-6 MBI INSTALL INTEL MBI DRIVER (FOR WIN 8/8.1 ONLY)	63
5-7 TXE INSTALL INTEL TXE DRIVER	65
5-7-1 TXE INSTALL FOR WIN8/WIN8.1	65
5-7-2 TXE INSTALL FOR WIN7	67
5-8 HOW TO UPDATE INSYDE BIOS	69
APPENDIX A:POWER CONSUMPTION TEST	70
APPENDIX B:RESOLUTION LIST	71
APPENDIX C:F75111N I C DIO DEVICE	72
1-1 IO DEVICE : F75111 UNDER DOS	72
1-2 IO DEVICE : F75111 UNDER WINDOWS	73
1-3 IO DEVICE : F75111 VB6 UNDER WINDOWS	76
1-4 IO DEVICE : F75111 UNDER LINUX	78

Copyright

This manual is copyrighted and all rights are reserved. It does not allow any non authorization in copied, photocopied, translated or reproduced to any electronic or machine readable form in whole or in part without prior written consent from the manufacturer.

In general, the manufacturer will not be liable for any direct, indirect, special, incidental or consequential damages arising from the use of inability to use the product or documentation, even if advised of the possibility of such damages.

The manufacturer keeps the rights in the subject to change the contents of this manual without prior notices in order to improve the function design, performance, quality, and reliability. The author assumes no responsibility for any errors or omissions, which may appear in this manual, nor does it make a commitment to update the information contained herein.

Trademarks

Intel is a registered trademark of Intel Corporation.

Award is a registered trademark of Award Software, Inc.

All other trademarks, products and or product's name mentioned here are for identification purposes only, and may be trademarks and/or registered trademarks of their respective companies or owners.

© Copyright 2015

All Rights Reserved.

User Manual edition 0.1, Oct. 21. 2015

Warning !

1. Battery
Batteries on board are consumables.
The life time of them are not guaranteed.
2. Fanless solution with HDD
The specification & limitation of HDD should be considered carefully when the fanless solution is implemented.
3. We will not give further notification in case of changes of product information and manual.
4. SATA interface does not support Hot SWAP function.
5. There might be a 20% inaccuracy of WDT at room temperature.
6. Please make sure the voltage specification meets the requirement of equipment before plugging in.
7. There are two types of SSD, commercial grade and industrial grade, which provide different read/write speed performance, operation temperature and life cycle. Please contact sales for further information before making orders.
8. Caution! Please notice that the heat dissipation problem could cause the MB system unstable. Please deal with heat dissipation properly when buying single MB set.
9. Please avoid approaching the heat sink area to prevent users from being scalded with fanless products.
10. If users repair, modify or destroy any component of product unauthorizedly, We will not take responsibility or provide warranty anymore.
11. DO NOT apply any other material which may reduce cooling performance onto the thermal pad.
12. It is important to install a system fan toward the CPU to decrease the possibility of overheating / system hanging up issues, or customer is suggested to have a fine cooling system to dissipate heat from CPU.

* Hardware Notice Guide

1. Before linking power supply with the motherboard, please attach DC-in adapter to the motherboard first. Then plug the adapter power to AC outlet.
Always shut down the computer normally before you move the system unit or remove the power supply from the motherboard. Please unplug the DC-in adapter first and then unplug the adapter from the AC outlet.
Please refer photo 1 as standard procedures.
2. In case of using DIRECT DC-in (without adapter), please check the allowed range for voltage & current of cables. And make sure you have the safety protection for outer issues such as short/broken circuit, overvoltage, surge, lightning strike.
3. In case of using DC-out to an external device, please make sure its voltage and current comply with the motherboard specification.
4. The total power consumption is determined by various conditions (CPU/motherboard type, device, application, etc.). Be cautious to the power cable you use for the system, one with UL standard will be highly recommended.
5. It's highly possible to burn out the CPU if you change/ modify any parts of the CPU cooler.
6. Please wear wrist strap and attach it to a metal part of the system unit before handling a component. You can also touch an object which is ground connected or attached with metal surface if you don't have wrist strap.
7. Please be careful to handle & don't touch the sharp-pointed components on the bottom of PCBA.
8. Remove or change any components from the motherboard will VOID the warranty of the motherboard.
9. Before you install/remove any components or even make any jumper setting on the motherboard, please make sure to disconnect the power supply first. (follow the aforementioned instruction guide)
10. "POWERON after PWR-Fail" function must be used carefully as below:
When the DC power adaptor runs out of power, unplug it from the DC current;
Once power returns, plug it back after 5 seconds.
If there is a power outage, unplug it from the AC current, once power returns, plug it back after 30 seconds. Otherwise it will cause system locked or made a severe damage.

Remark 1:

Always insert/unplug the DC-in horizontally & directly to/from the motherboard. DO NOT twist, it is designed to fit snugly.

Moreover, erratic pull / push action might cause an unpredictable damage to the component & system unit.

Photo 1

Insert

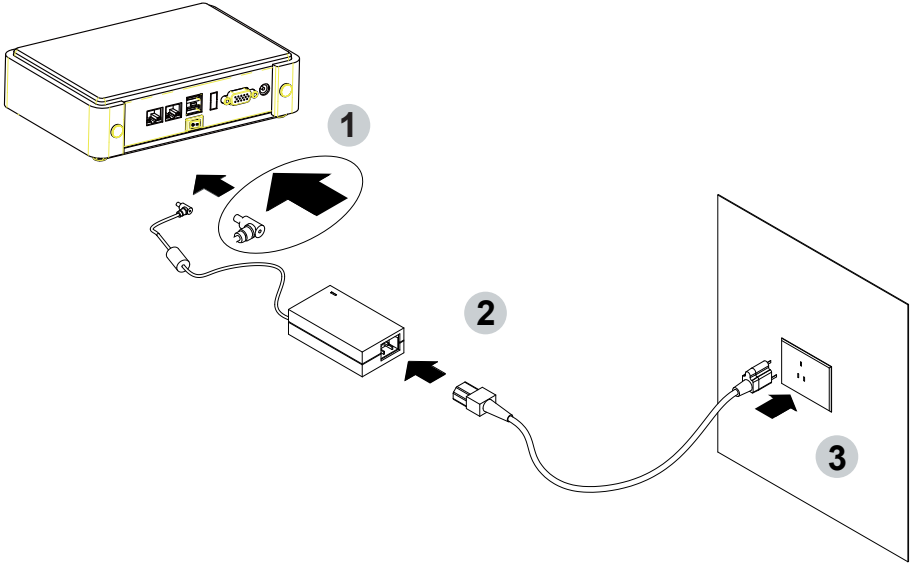

Unplug

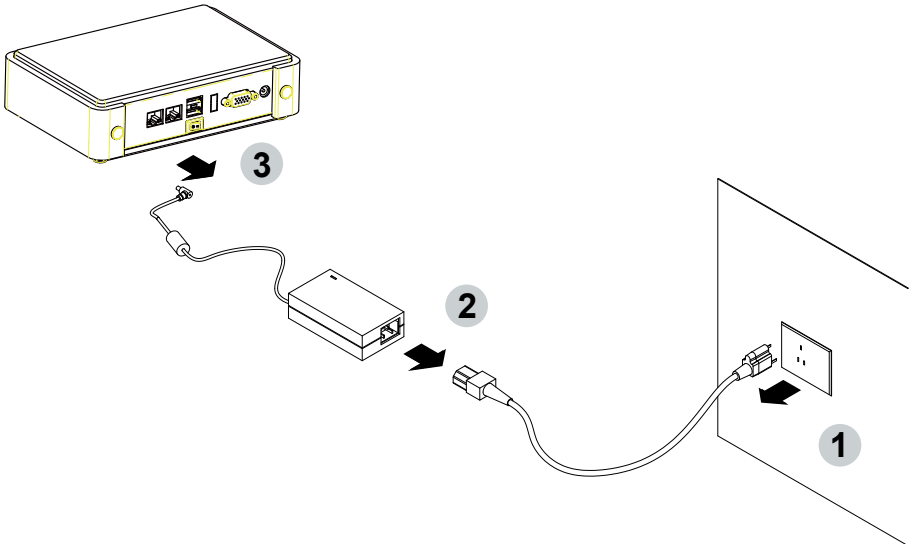

Chapter-1

General Information

The 2I385S is a 2.5 inches form factor All-In-One Board. The board design combines all necessary input and output interfaces, which makes itself an ideal all-in-one control board for POS, Digital Signage and Automation application. Due to its compact size, 2I385S is also the perfect platform for a whole range of small form factor and low-power devices, such as mobile PC or small panel PC

The 2I385S All-In-One motherboard is with Intel BayTrail-D J1900 2.0GHz CPU (Quad core processor), Intel BayTrail-D J1900 2.0GHz chipset and BayTrail-D Integrated Graphics chipset. This integrated platform offers superb performance and PC specification in the industry. Despite the limited space of 2I385S, it supports 1 ports of Hi-Speed USB 3.0 / 2.0 and 2 ports of USB 2.0 to enhance the host controller interface which will ensure the high performance level and flexible expansion.

The 2I385S supports two LAN ports of 10/100/1000 Ethernet for various and seamless broadband connectivity. With Wake-On LAN function and the PXE function in BIOS, these are perfect control boards for networking devices. The built-in LAN is Intel I211AT LAN chipset for PCIe x 1 V2.1 interface, integrated 10/100/1000 transceiver.

The 2I385S motherboard is built in with onboard DDR3L SDRAM 2GB Memory DDR3 data transfer rate of 1333MT/s. The expendable interfaces include one full size PCIe Mini card for PCIe, mSATA and USB interface, one half size PCIe Mini card for mSATA and USB interface.

The supported display interfaces include VGA, HDMI and mini HDMI. The board has a small footprint of only 102 x 73 mm (2.5 inch) and advanced performance in both computing and graphics.

The All-In-One motherboard 2I385S is fully compatible with industrial standards, plus technical enhancements and thousands of software applications developed for IBM PC/AT compatible computers. These control logic provides high-speed performance for the most advanced multi user and multitasking applications available today.

1-1 Major Feature

1. Intel BayTrail-D D1900 2.0GHz SOC (Quad core)
2. Intel BayTrail-D Integrated Graphics chipset, 688 MHz render clock frequency
3. On board DDR3L SDRAM 2GB Memory, data transfer rate of 1333MT/s
4. Support 2 x 10/100/1000 Mbps Intel LAN ports
5. Support 1 x USB 3.0 / 2.0, 1 x USB 2.0, 1 x micro USB 2.0
6. Support extended 2 x Mini PCIe card (full size & half size)
7. Support one SATA connector with independent DMA operation supported
8. Hardware Watch Dog Timer, 0~255 sec programmable
9. On board DC +12V
10. PCB Dimension: 102 x 73 mm (2.5 inch)
11. Display interfaces include VGA, HDMI and mini HDMI

1-2 Specification

1. SOC: Intel BayTrail-D J1900 2.0GHz (Quad core)
2. Memory: DDR3L SDRAM 2GB Memory, data transfer rate of 1333MT/s
3. Graphics: Intel BayTrail-D Integrated Graphics chipset,
J1900 688 MHz render clock frequency
4. SATA: One SATA connector with independent DMA operation supported
5. LAN: LAN: 2 x INTEL I211-AT / I210-IT (option) PCIE LAN of 10 / 100 / 1000 Mbps
6. USB: 1 x USB 3.0 / 2.0, 1 x USB 2.0, 1 x micro USB 2.0
7. Sound: ALC886 HD Audio Specification 1.0 Two channel sound chipset
8. WDT: Hardware Watch Dog Timer, 0~255 sec programmable
9. Expansion interface: one full size PCIe Mini card for PCIe, mSATA and USB interface,
one half size PCIe Mini card for mSATA and USB interface
10. BIOS: Insyde UEFI BIOS
11. Dimension: 102 x 73 mm (2.5 inch)
12. Power: On board DC +12V

1-3 Installing the Mini PCI-e Card

1. Unfasten the round-headed M2*6 screw for half size Mini PCI-e.



2. Install a mSATA card at the angle of 45°. (The half size Mini PCI-e slot supports mSATA)



3. Fasten a round-headed M2*6 screw.



1-4 Directions for installing the Mini Card

1. Unscrew the screw on the board



2. Plug in the Mini Card in a 45 angle



3. Gently push down the Mini Card and screw the screw back.



1-5 Packing List

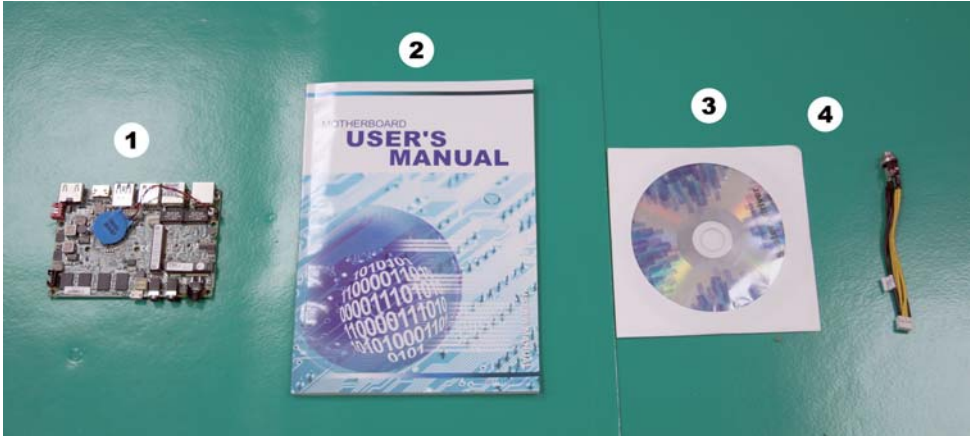

	Material Code	Description	Detail Specification	Quantity
1	7G1901-1590001-0	MB-2I385S-D92-001	LF,2I385S-D92,Rev.:001	1
2	6G8001-2196-0400	Manual	LF,M/B,2I385S	1
3	6G8006-2349-0100	LEX Product Driver DVD	LF, Intel Baytrail Driver,Windows 7/8.1 32/64	1
4	6G6003-7330-0100	Power Cable	LF,L=9cm,2.0 1*4/DC JK	1

**Optional accessories (items in addition to motherboard)
are not included in the standard packing.
Please contact your dealer to purchase the optional accessories.**

Chapter-2

Hardware Installation

2-1 Unpacking Precaution

This chapter provides the information how to install the hardware of 2I385S. Please follow section 1-5, 2-1 and 2-2 to check the delivery package and unpack carefully. Please follow the jumper setting procedure.

NOTE!

1. Do not touch the board or any other sensitive components without all necessary anti-static protection.
2. Please pay attention to the voltage limitation of DC-IN 12V 5%.
Overuse of DC-IN voltage limitation or change to another power adapter (not provided with this system) will VOID warranty.

You should follow these steps to protect the board from the static electric discharge whenever you handle the board:

1. Ground yourself by a grounded wrist strap at all times when you handle the 2I385S. Well secure the ALLIGATOR clip of the strap to the end of the shielded wire lead from a grounded object. Please put on and connect the strap before handling the 2I385S for harmlessly discharge any static electricity through the strap.
2. Please use anti-static pad to put any components, parts, or tools on the pad whenever you work on them outside the computer. You may also use the anti-static bag instead of the pad. Please ask your local supplier for necessary parts on anti-static requirement.
3. Do not plug any connector or set any jumper when the power is on.

2-2 Unpacking checkup

First of all, please follow all necessary steps of section 2-1 to protect 2I385S from electricity discharge. With reference to section 1-5 please check the delivery package again with following steps:

1. Unpack the 2I385S board and keep all packing material, manual and driver disc etc, do not dispose !
2. Is there any components lose or drops from the board?
DO NOT CONTINUE TO INSTALL THIS BOARD!
CONTACT THE DEALER YOU PURCHASED THIS BOARD FROM, IMMEDIATELY.
3. Is there any visible damage on the board?
DO NOT CONTINUE TO INSTALL THIS BOARD!CONTACT THE DEALER YOU PURCHASED THIS BOARD FROM, IMMEDIATELY.
4. Check your optional parts (i.e. DDR, CF etc.), all necessary jumpers setting to jumper pin-set, and CMOS setup correctly.
Please also refer to all information of jumper settings in this manual.
5. Check your external devices (i.e. Add-On-Card, Driver Type etc.) for complete add-in or connection and CMOS setup correctly.
Please also refer to all information of connector connection in this manual.
6. Please keep all necessary manual and driver disc in a good condition for future re-installation if you change your Operating System.

2-3 Dimension-2I385S

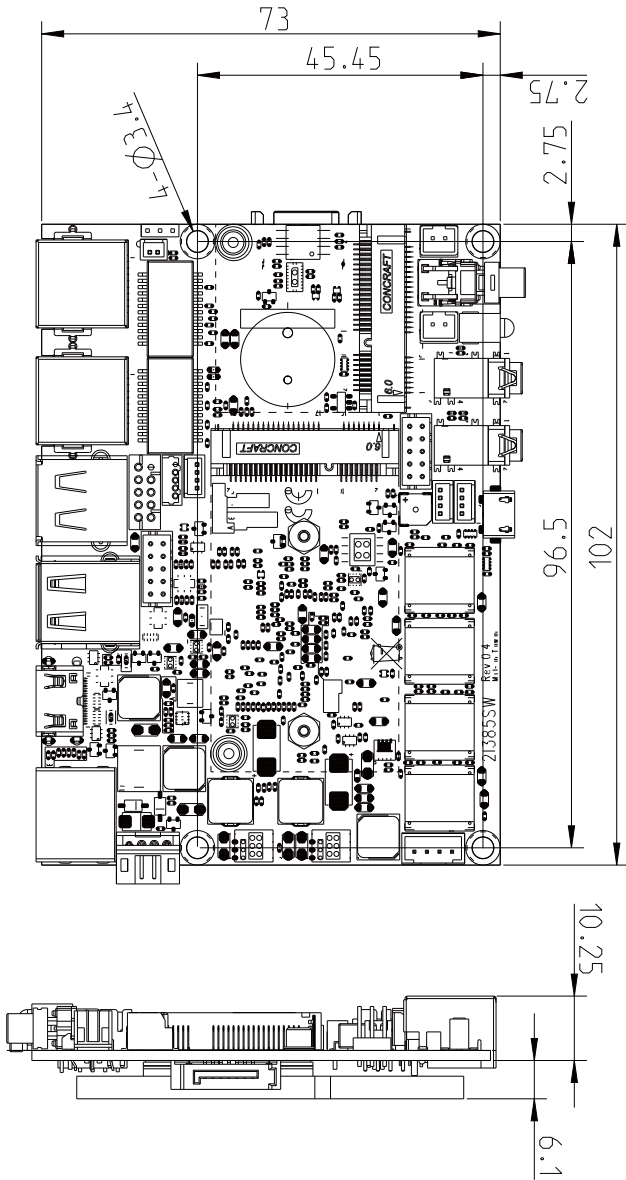

2-4 Layout-2I385S-Connector and Jumper

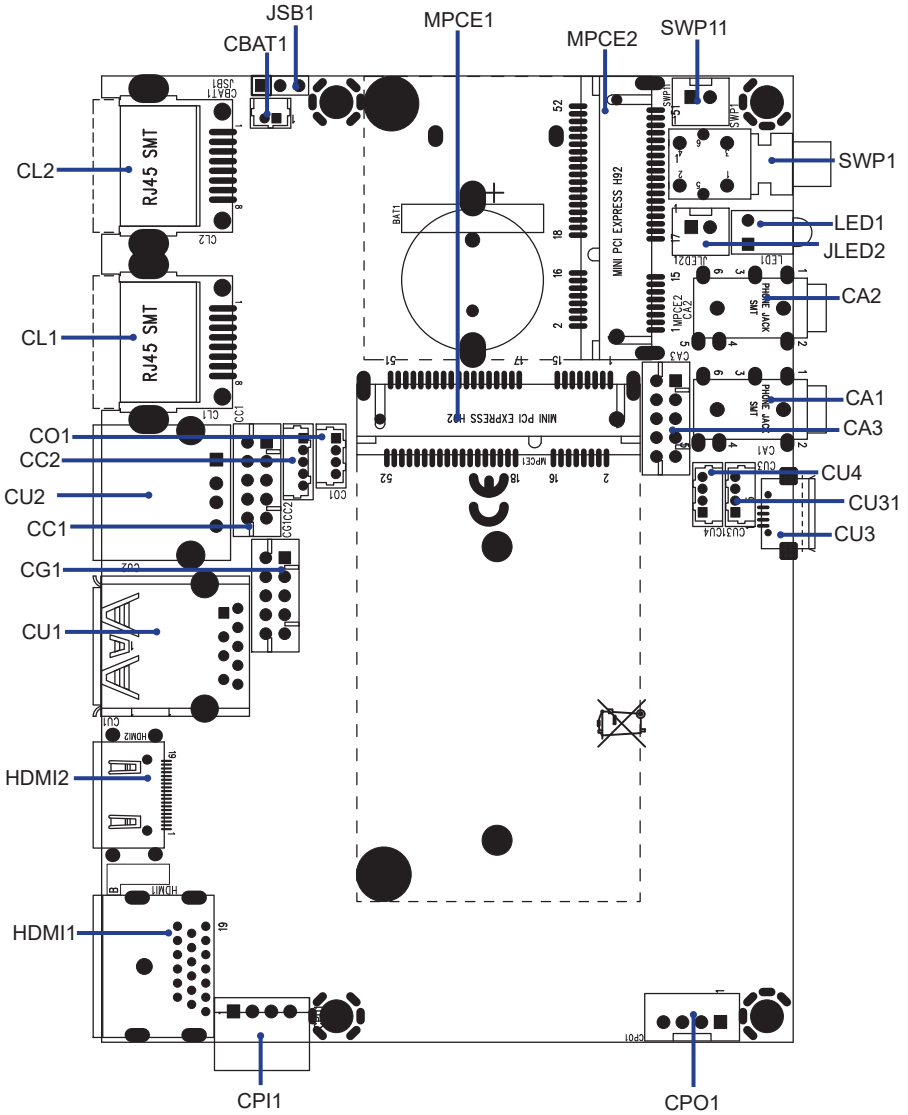

2-4-1 Layout-2I385S-Connector and Jumper Bottom

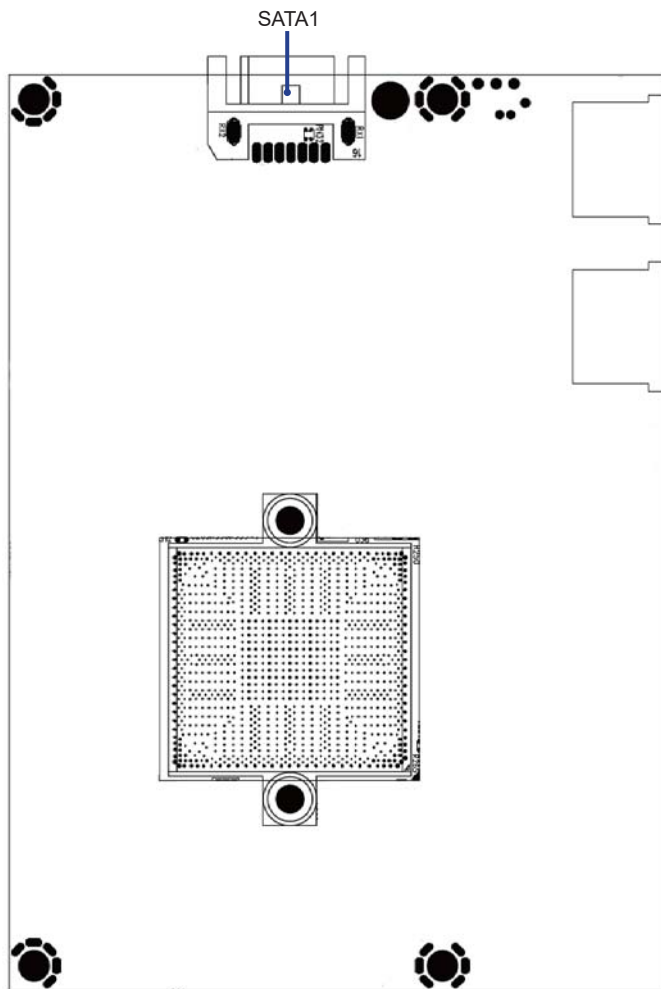

2-5 Diagram- 2I385S

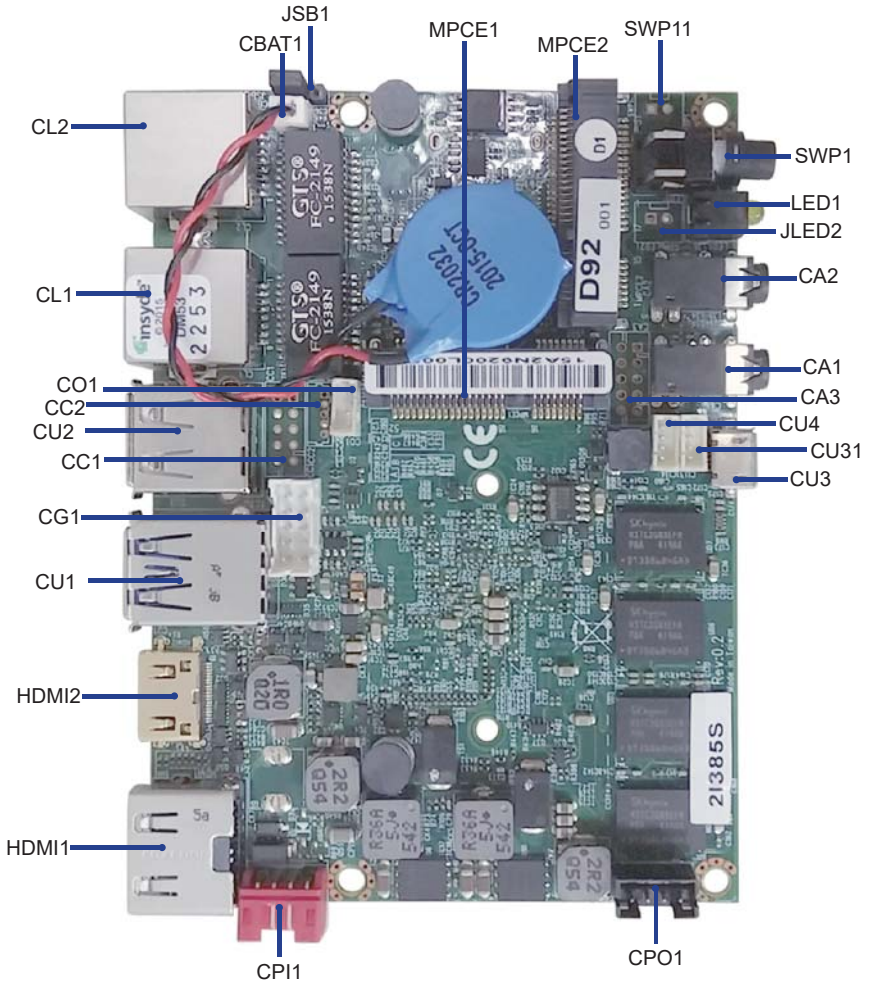

Front Panel

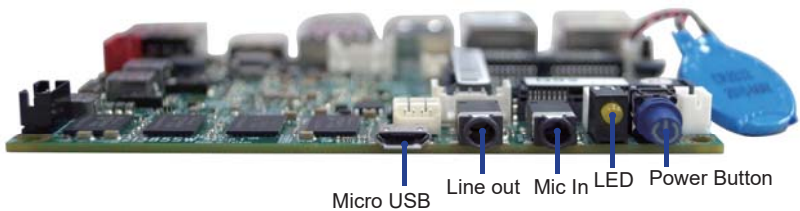

2-5-1 Bottom Side Diagram- 2I385S

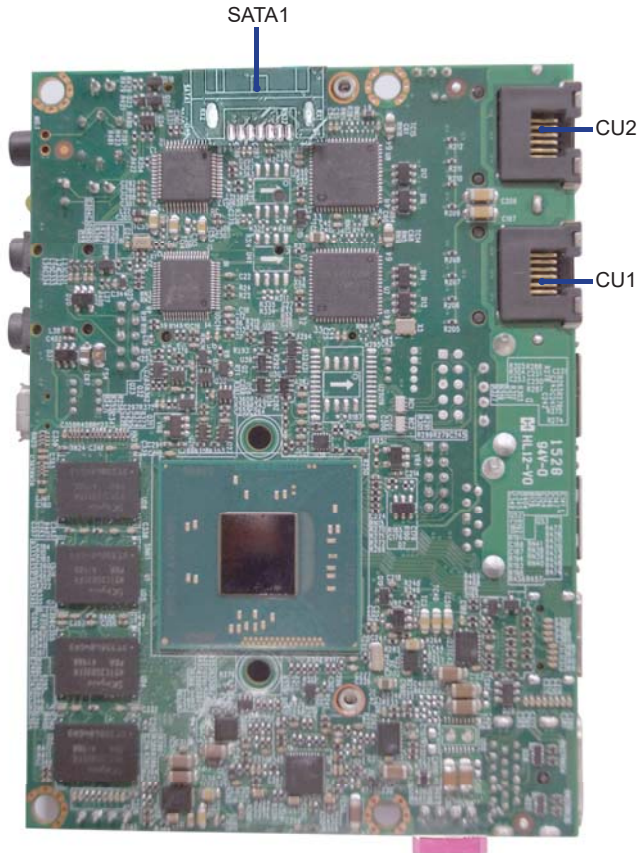

BACK Panel

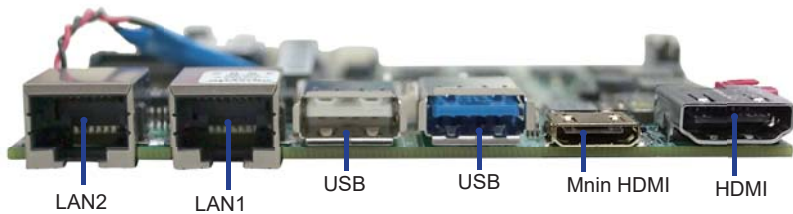

2-6 List of Jumpers

JSB1: CMOS DATA clear

2-7 Jumper Setting Description

A jumper is ON as a closed circuit with a plastic cap covering two pins. A jumper is OFF as an open circuit without the plastic cap. Some jumpers have three pins, labeled 1, 2, and 3. You could connect either pin 1 and 2 or 2 and 3.

The below figure 2.2 shows the examples of different jumper settings in this manual.

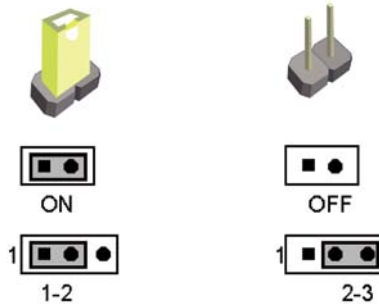

Figure 2.2

All jumpers already have its default setting with the plastic cap inserted as ON, or without the plastic cap as OFF. The default setting may be referred in this manual with a " * " symbol .

2-8 JSB1: CMOS Data Clear

A battery must be used to retain the motherboard configuration in CMOS RAM. Close Pin1 and pin 2 of JSB1 to store the CMOS data.

To clear the CMOS, follow the procedures below:

1. Turn off the system and unplug the AC power
2. Remove DC 12V power cable from DC 12V power connector
3. Locate JSB1 and close pin 1-2 for few seconds
4. Return to default setting by close pin 1-2
5. Connect DC 12V power cable back to DC 12V Power connector

JSB1	Description
*1-2	Normal set
2-3	CMOS data clear

Note: Normal work is open jumper

Note: Do not clear CMOS unless

- 1. Troubleshooting**
- 2. Forget password**
- 3. You fail over-clocking system**

JSB1



*Normal



COMS

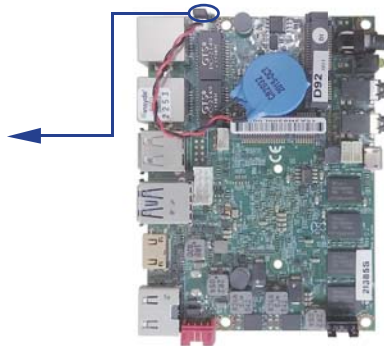

Chapter-3

Connection

This chapter provides all necessary information of the peripheral's connections, switches and indicators. Always power off the board before you install the peripherals.

3-1 List of Connectors

BAT1: Li 3V battery holder

CBAT1: Li 3V battery 2pin (1.25mm) wafer

CA1: Line out Phoen Jack

CA2: Mic In Phoen Jack

CA3: Line-out/Line-in/Mic-in/SPDIF-out 2x5 pin (2.0mm) Wafer (Option)

CC1: COM 2x5pin (2.0mm) wafer (Option)

CC2: COM 1x5pin (1.25mm) wafer (Option)

CG1: VGA port 2x5pin (2.0mm) wafer

CL1/CL2: LAN RJ45 connector

CO1: I²C 4pin (1.25mm) wafer

CPI1: DC-in 1x4 pin 180°(2.0mm) Red wafer connector (Option)

CPI11: DC-in 1x4 pin 90°(2.0mm) Red wafer connector

CPO1: DC +5/+12V output 1x4 pin(2.0mm) Black wafer connector

CU1: USB USB3.0/2.0 connector

CU2: USB USB 2.0 connector

CU3: Micro USB 2.0

CU31/CU4: USB port 4pin(1.25mm) wafer

HDMI1: HDMI type A connector

HDMI2: Mini HDMI type C connector

JLED2: HDD LED 1x2pin (2.00mm) Wafer connector (Option)

LED1: LAN Active LED

MPCE1: Full size Mini card port 2 sockets 52pin

MPCE2: Half size Mini card port 1 sockets 52pin

SWP11: Power Button 1x2pin (2.00mm) Wafer connector (Option)

SPW1: Power LED (Blue) / Power Button Switch

SATA1: SATA port 0 (Gen II) connectors 7pin (Option)

3-2 DC-IN Internal Connector

● CPI1: DC-IN Internal Connector (1 X 4 pin 180°2.0mm Red wafer) (Option)

PIN NO.	Description
1	GND
2	DC-IN
3	DC-IN
4	GND

- Note: 1. DC in from adapter plug in
2. Mating connector: JST B4B-PH-KL or compatible
3. Cable housing: JST PHR-4 or compatible

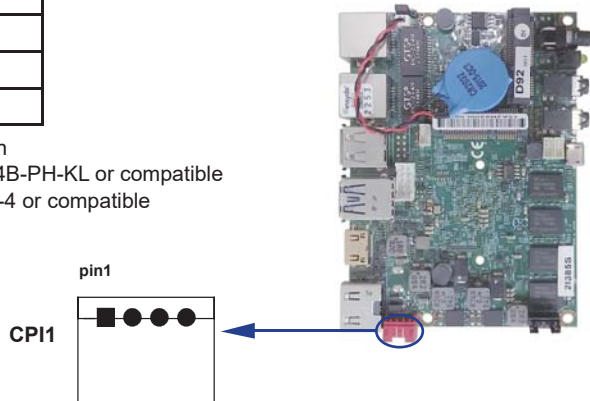

● CPI11: DC-IN Internal Connector (1 X 4 pin 90°2.0mm Red wafer)

PIN NO.	Description
1	GND
2	DC-IN
3	DC-IN
4	GND

- Note: 1. DC in from adapter plug in
2. Mating connector: JST B4B-PH-KL or compatible
3. Cable housing: JST PHR-4 or compatible

3-3 CMOS Battery connector

- **BAT1: 3V Battery hold 2pin**

BAT1: Battery use Li 3V / 220mAh (CR2032)

Note: 1. When board without Adaptor plug in, this board power RTC consumption about 2.7uA
2. If adaptor always plug in RTC power consumption about 0.1uA

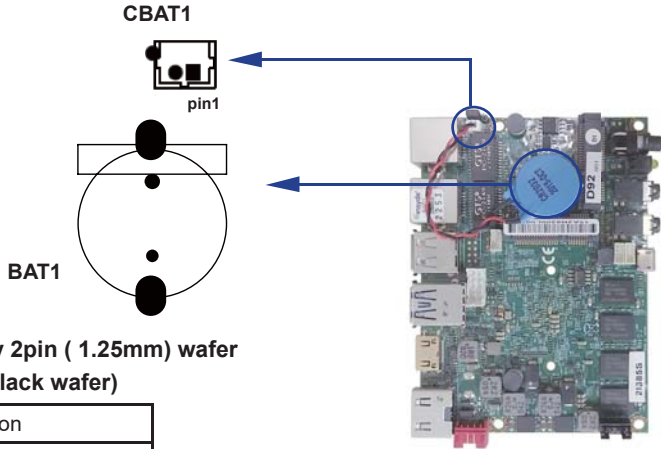

- **CBAT1: 3V Battery 2pin (1.25mm) wafer (1 X 2 pin 2.0mm Black wafer)**

PIN NO.	Description
1	GND
2	VBAT *

3-4 DC+12V /+5 Voltage output

● CPO1: +12V/+5V DC voltage output (1 X 4 pin 2.0mm Black wafer)

PIN NO.	Description
1	+5V
2	GND
3	GND
4	+12V*

- *Note: 1. DC in +12V by switch to DC-out voltage +12V, so DC in need stable +12V input
 2. Mating connector: JST B4B-PH-KL or compatible
 3. Cable housing: JST PHR-4 or compatible

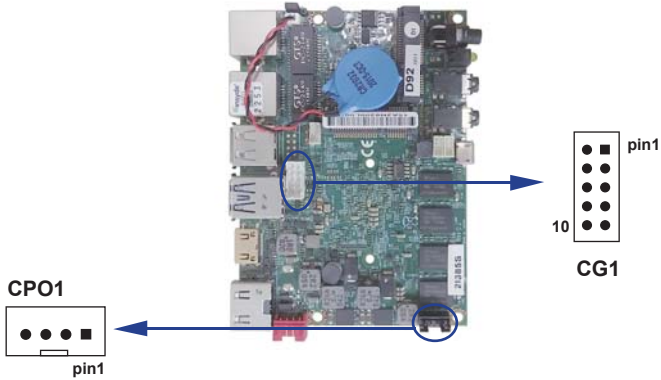

3-5 VGA wafer

● CG1: VGA wafer (2x5pin 2.0mm wafer)

PIN NO.	Description	PIN NO.	Description
1	BLUE	2	GND
3	GND	4	DDC CLOCK
5	GREEN	6	V-SYNC
7	GND	8	H-SYNC
9	RED	10	DDC-DATA

- Note: 1. Mating connector: JST B10B-PHDSS or compatible
 2. Cable housing: JST PHDR-10VS or compatible

3-6 COM interface

● CC1: COM1 RS232 Mode 2x5 pin (2.0mm) Wafer (Option)

PIN NO.	Description	PIN NO.	Description
1	DCD	2	RXD
3	TXD	4	DTR
5	GND	6	DSR
7	RTS	8	CTS
9	RI	10	+5V

Note: 1. Mating connector: JST B10B-PHDSS or compatible
2. Cable housing: JST PHDR-10VS or compatible

● CC1: COM1 RS485 Mode 2x5 pin (2.0mm) Wafer (Option)

PIN NO.	Description	PIN NO.	Description
1	RS485 TX-	2	RS485 TX+
3	NC	4	NC
5	GND	6	NC
7	NC	8	NC
9	NC	10	+5V

Note: 1. CC1 connector RS485 function for OEM BOM request
2. BIOS need setting to RS485 mode
3. Mating connector: JST B10B-PHDSS or compatible
4. Cable housing: JST PHDR-10VS or compatible

● CC2: COM2 TTL Mode 1x5 pin (1.25mm) Wafer (Option)

PIN NO.	1	2	3	4	5
Description	+5V	GND	RTS	TX	RX

Note: 1. All signal are TTL level

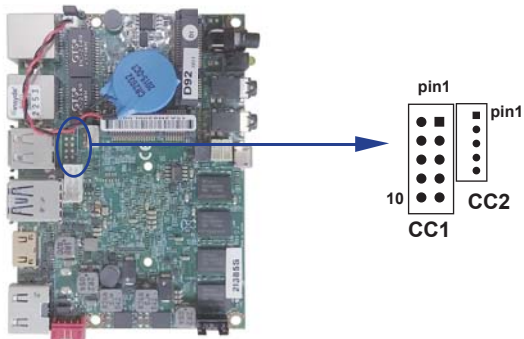

3-7 Audio interface

• CA1: Line out connector (3.5mm Phone jack)

PIN NO.	1	2	3	4	5
Description	GND	NC	Line-out-R	Line-out-L	NC

• CA2: Mic In connector (3.5mm Phone jack)

PIN NO.	1	2	3	4	5
Description	GND	NC	NC	Mic In	NC

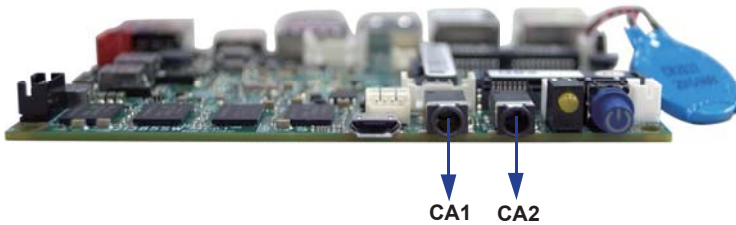

• CA3: Line-out/Line-in/Mic-in/SPDIF-out 2x5 pin (2.0mm) Wafer (Option)

PIN NO.	Description	PIN NO.	Description
1	Line-out-R	2	MIC-IN
3	Line-in-R	4	GND
5	GND	6	SPDIF-OUT
7	Line-in-L	8	+5V
9	Line-out-L	10	MIC-IN

- Note: 1. Mating connector: JST B10B-PHDSS or compatible
 2. Cable housing: JST PHDR-10VS or compatible

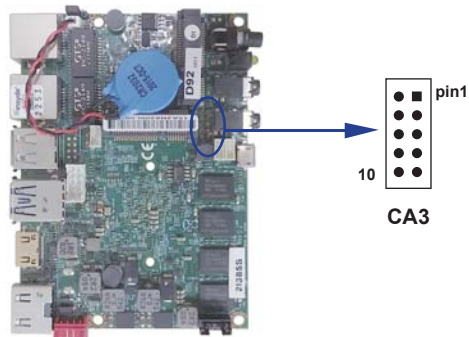

● **WDT For F75111N I²C watch dog timer device:**

DC spec :

Input low Voltage (VIL):+0.8 Max ,

Input High Voltage(VIH) : +2V Min

Output low Current (IOL):10mA (Min) VOL=0.4V

Output High Current (IOH):-10mA (Min) VOH=2.4V

Watch Dog Time value 0~255 sec

The system will be issued reset. When WDT is enable the hardware start down counter to zero.

The reset timer have 10~20% tolerance upon the Temperature.

Note: If want to SDK support. Please contact to sales window.

Please refer to page 82 for APPENDIX C: F75111N I²C DIO DECICE

3-8 I²C Bus Interface

● **CO1: I²C (SM) bus connector (1 X 4 pin 1.25mm wafer)**

PIN NO.	1	2	3	4
Description	+3.3V	GND	SMB_CLK	SMB_DATA

Note: 1. Mating connector: MOLEX 53047-0410 or compatible

2. Cable housing: MOLEX 51021-0400 or compatible

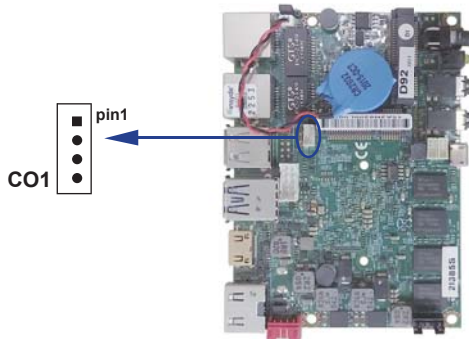

3-9 LAN Interface

• CL1/CL2 : RJ45 LAN port Giga /100Mb(RJ45 Jack)

PIN NO.	Description	PIN NO.	Description
1	TR0-/TX+	5	TR2-/NC
2	TR0-/TX-	6	TR1-/RX-
3	TR1+/RX+	7	TR3+/NC
4	TR2+/NC	8	TR3-/NC



3-10 USB Interface

● CU1: USB3.0/2.0 port (Type A connector)

PIN NO.	Description	PIN NO.	Description
		1	USB 3.0 TX+
1	+5V		
2	USB 2.0 D-	2	USB 3.0 TX-
		3	GND
3	USB 2.0 D+	4	USB 3.0 RX+
4	GND		
		5	USB 3.0 RX-

Note: 1. USB 3.0 and USB 2.0 combo Type A Jack

2. USB3.0/2.0 Keyboard and Mouse use CU1 can pitch Some OS install
And wake up Keyboard and Mouse can't work issue

● CU2: USB 2.0 port (Type A connector)

PIN NO.	Description
1	+5V
2	USB DATA -
3	USB DATA +
4	GND

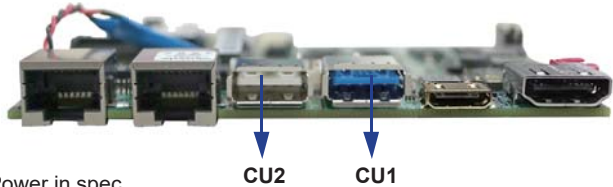

Note: 1. Attention! Check Device Power in spec

● CU3: Micro USB 2.0 ports (Type B connector)

PIN NO.	Description
1	+5V
2	USB DATA -
3	USB DATA +
4	NC
5	GND

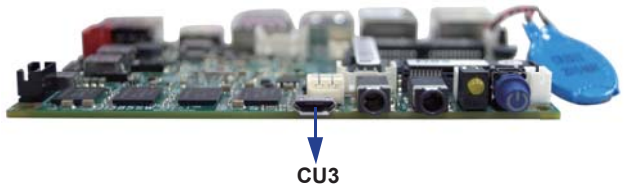

Note: 1. CU3 Share CU31 & MPCE2

● CU31/CU4: USB2.0 Port (1x4pin 1.25mm Wafer)

PIN NO.	Description
1	+5V
2	USB DATA -
3	USB DATA +
4	GND

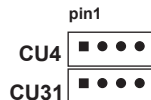

Note: 1. Attention! Check Device Power in spec

2. Mating connector: MOLEX 53047-0410 or compatible

3. Cable housing: MOLEX 51021-0400 or compatible

4. CU31 Share CU3 & MPCE2

5. CU4 Share MPCE1

3-10 HDMI Interface

• HDMI1: HDMI Connector (Type A)

PIN NO.	Description	PIN NO.	Description
1	TMDS DATA2+	2	GND
3	TMDS DATA2-	4	TMDS DATA1+
5	GND	6	TMDS DATA1-
7	TMDS DATA0+	8	GND
9	TMDS DATA0-	10	TMDS CLK+
11	GND	12	TMDS CLK-
13	NC	14	NC
15	DDC CLK	16	DDC DATA
17	GND	18	+5V
19	H.P. Detect		

*Note: HDMI support 1.3a Spec

• HDMI2: Mini HDMI Connector (Type C)

PIN NO.	Description	PIN NO.	Description
1	GND	2	TMDS DATA2+
3	TMDS DATA2-	4	GND
5	TMDS DATA1+	6	TMDS DATA1-
7	GND	8	TMDS DATA0+
9	TMDS DATA0-	10	GND
11	TMDS CLK+	12	TMDS CLK-
13	GND	14	NC
15	DDC CLK	16	DDC DATA
17	NC	18	+5V
19	H.P. Detect		



3-12 LED

- JLED2: HDD LED 1x2pin (2.00mm) Wafer (Option)

PIN NO.	Description
1	HDD LED+
2	HDD LED-

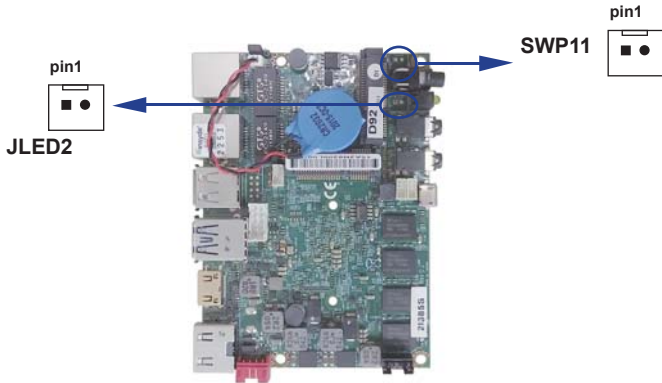

3-13 Power button connector

- SWP11: Power Button 1x2pin (2.00mm) Wafer connector (Option)

PIN NO.	Description
1	Power Button+
2	Power Button-

3-14 Mini PCIe socket

●MPCE1/MPCE2: Support USB and PCIe by one Interface
(Mini card socket 52pin)

PIN NO.	Description	PIN NO.	Description
1	NC	2	+3.3V
3	NC	4	GND
5	NC	6	+1.5V
7	NC	8	NC
9	GND	10	NC
11	PCIe-CLK-	12	NC
13	PCIe-CLK+	14	NC
15	GND	16	NC
KEY	KEY	KEY	KEY
17	NC	18	GND
19	NC	20	NC
21	GND	22	RST-
23	PCIe-RX-/mSATA-RX+	24	+3.3V
25	PCIe-RX+/mSATA-RX-	26	GND
27	GND	28	+1.5V
29	GND	30	SMB-CLK
31	PCIe-TX-/mSATA-TX-	32	SMB-DATA
33	PCIe-TX+/mSATA-TX+	34	GND
35	GND	36	USB-DATA-
37	GND	38	USB-DATA+
39	+3.3V	40	GND
41	+3.3V	42	NC
43	NC	44	NC
45	NC	46	NC
47	NC	48	+1.5V
49	NC	50	GND
51	mSATA-Detect	52	+3.3V

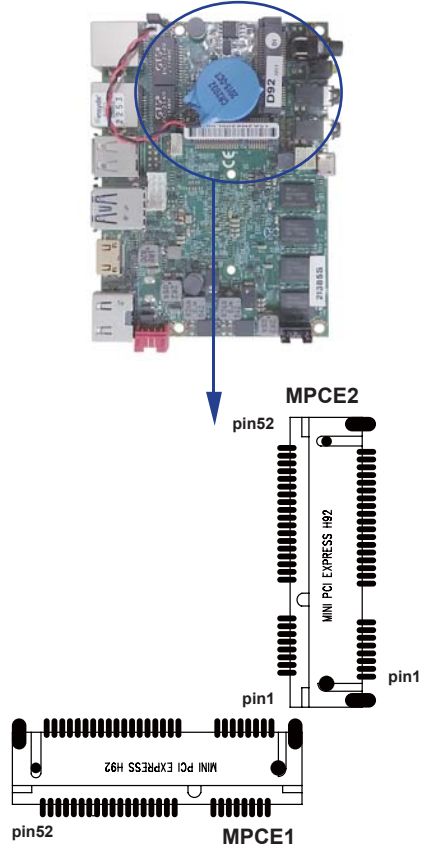

- Note:
1. MPCE1 Full size, MPCE2 Half size
 2. MPCE1 Pin23, 25, 31, 33 supported mSATA device and PCIe device alternatively
 3. MPCE1 Pin51 mSATA / PCIe auto detect function
 4. MPCE1 USB Share CU4
 5. MPCE2 Pin 23,25,31,33 for mSATA device Only
 6. MPCE2 USB Share CU3 & CU1

3-15 SATA Interface

• SATA1: SATA connectors (Option)

PIN NO.	Description
1	GND
2	DATA TX+
3	DATA TX-
4	GND
5	DATA RX-
6	DATA RX+
7	GND

- Note: 1. SATA1 support SATA 2.0 spec update 6Gb/sec .
2. CPO1 provide SATA HDD power +12V, GND, +5V
3. The SATA signal share with mSATA of MPCE1,
but just one can be worked in same time.

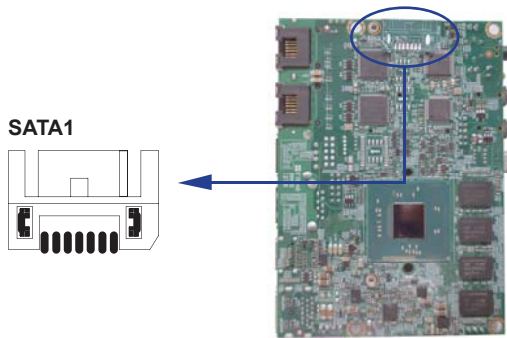

Chapter-4

Introduction of BIOS

The BIOS is a program located in the Flash Memory on the motherboard.

This program is a bridge between motherboard and operating system.

When you start the computer, the BIOS program gains control.

The BIOS first operates an auto-diagnostic test called POST (Power on Self Test) for all the necessary hardware, it detects the entire hardware devices and configures the parameters of the hardware synchronization. After these tasks are completed, BIOS will give control of the computer back to operating system (OS).

Since the BIOS is the only channel for hardware and software to communicate with, it is the key factor of system stability and of ensuring your system performance at best.

In the BIOS Setup main menu, you can see several options. We will explain these options in the following pages. First, let us see the function keys you may use here:

Press <Esc> to quit the BIOS Setup.

Press ↑↓←→(up, down, left, right) to choose the option you want to confirm or modify.

Press <F10> to save these parameters and to exit the BIOS Setup menu after you complete the setup of BIOS parameters.

Press Page Up/Page Down or +/- keys to modify the BIOS parameters for the active option.

4-1 Enter Setup

Power on the computer and press key immediately to enter Setup.

If the message disappears before your respond but you still wish to enter Setup, restart the system by turning it OFF then ON. You may also restart the system by simultaneously pressing <Ctrl>, <Alt> and <Delete> keys.

4-2 BIOS Menu Screen & Function Keys

InsydeH20 Setup Utility		Rev. 5.0			
Main	Advanced	Security	Power	Boot	Exit
BIOS Version	2I385S D1				
Build Date	09/15/2015				
Build Time	09:35:20				
Processor Type	Intel(R) Celeron(R) CPU J1900 @ 1.99GHz				
System Memory Speed	1333 MHz				
Cache RAM	2048 KB				
Total Memory	2048 MB				
System Time	[00:00:00]				
System Date	[01/01/2015]				
F1 Help	↑ ↓ Select	F5/F6 Change Values	F9 Setup Defaults		
Esc Exit	← Select Menu	Enter Select ► SubMenu	F10 Save and Exit		

In the above BIOS Setup main menu of, you can see several options.

We will explain these options step by step in the following pages of this chapter, but let us first see a short description of the function keys you may use here:

- Press ←→ (left, right) to select screen;
- Press ↑↓ (up, down) to choose, in the main menu, the option you want to confirm or to modify.
- Press <Enter> to select.
- Press <+>/<-> keys when you want to modify the BIOS parameters for the active option.
- [F1]: General help.
- [F2]: Previous value.
- [F3]: Optimized defaults.
- [F4]: Save & Reset.
- Press <Esc> to quit the BIOS Setup.

4-3 Getting Help

InsydeH20 Setup Utility					Rev. 5.0
Main	Advanced	Security	Power	Boot	Exit
[General Help]					
<p>The Setup Utility is a ROM-based configuration utility that displays the system's configuration status and provides users with a tool to set their system parameters. Setting incorrect values may cause system boot failure:</p>					
<p>Load setup default values to recover</p>					
<p><Left/Right> Select Screen</p>					
<p><Up/Down> Select Item</p>					
<p><Enter> Select or Enter SubMenu</p>					
<p><F9> Load Setup Default</p>					
<p><F10> Save and Exit</p>					
<p><ESC> Exit Setup</p>					
<p><F1> key displays General Help(This Screen)</p>					
<p>Push Enter/ESC -- Leave</p>					
<p>Push PageUp -- previous</p>					
<p>Push PageDown -- Next Page</p>					
F1 Help	↑ ↓ Select	F5/F6 Change Values	F9 Setup Defaults		
Esc Exit	← Select Menu	Enter Select ► SubMenu	F10 Save and Exit		

Status Page Setup Menu/ Option Page Setup Menu

Press F1 to pop up a help window that describes the appropriate keys to use and the possible selections for the highlighted item. To exit the Help Window, press <Esc>.

4-4 Menu Bars

There are six menu bars on top of BIOS screen:

Main To change system basic configuration

Advanced To change system advanced configuration

Security Password settings

Power PME & Power button settings

Boot Exit Save setting, loading and exit options.

User can press the right or left arrow key on the keyboard to switch from menu bar.

The selected one is highlighted.

4-5 Main

InsydeH20 Setup Utility		Rev. 5.0			
Main	Advanced	Security	Power	Boot	Exit
BIOS Version	2I385S D1				
Build Date	09/15/2015				
Build Time	09:35:20				
Processor Type	Intel(R) Celeron(R) CPU J1900 @ 1.99GHz				
System Memory Speed	1333 MHz				
Cache RAM	2048 KB				
Total Memory	2048 MB				
System Time	[00:00:00]				
System Date	[01/01/2015]				

F1 Help	↑ ↓ Select	F5/F6 Change Values	F9 Setup Defaults
Esc Exit	← Select Menu	Enter Select ► SubMenu	F10 Save and Exit

Main menu screen includes some basic system information. Highlight the item and then use the <+> or <-> and numerical keyboard keys to select the value you want in each item.

System Date

Set the Date. Please use [Tab] to switch between data elements.

System Time

Set the Time. Please use [Tab] to switch between data elements.

4-6 Advanced

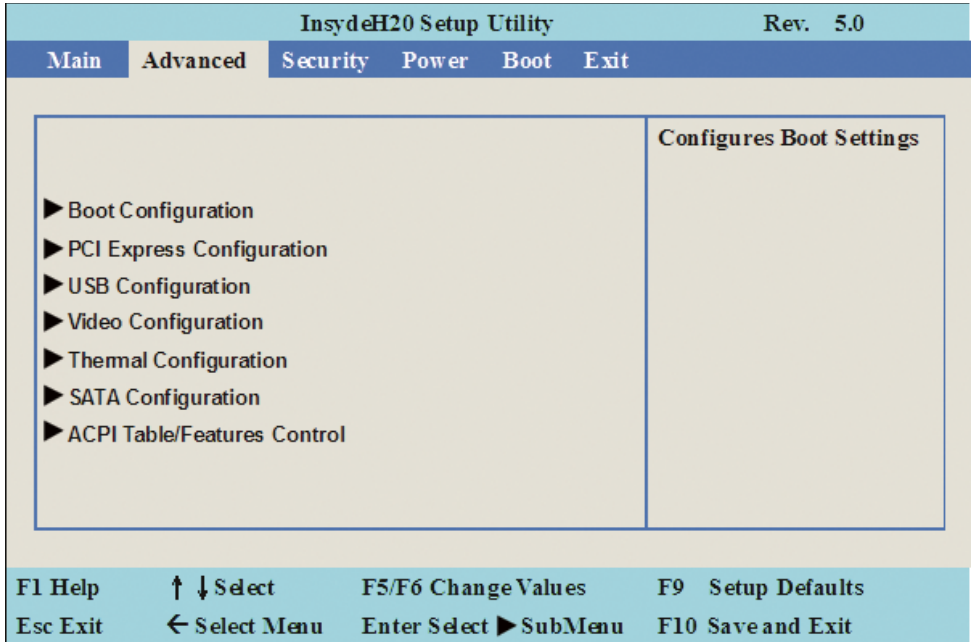

Boot Configuration

Please refer section 4-6-1

PCI Express Configuration

Please refer section 4-6-2

USB Configuration

Please refer section 4-6-3

Video Configuration

Please refer section 4-6-4

Thermal Configuration

Please refer section 4-6-5

SATA Configuration

Please refer section 4-6-6

ACPI Table/Features Control

Please refer section 4-6-7

4-6-1 Boot Configuration

InsydeH20 Setup Utility		Rev. 5.0	
Advanced			
Boot Configuration		Selects Power-on state For Numlock	
Numlock	<On>		
F1 Help	↑ ↓ Select	F5/F6 Change Values	F9 Setup Defaults
Esc Exit	← Select Menu	Enter Select ► SubMenu	F10 Save and Exit

Numlock

Select Power-on state for Numlock, default is <ON>

4-6-2 PCI Express Configuration

InsydeH20 Setup Utility		Rev. 5.0	
Advanced			
PCI Express Configuration		Control the PCI Express Root Port.	
► PCE Express Root Port 1			
► PCE Express Root Port 2			
► PCE Express Root Port 3			
F1 Help	↑ ↓ Select	F5/F6 Change Values	F9 Setup Defaults
Esc Exit	← Select Menu	Enter Select ► SubMenu	F10 Save and Exit

PCIe 1/2/3 configuration settings

4-6-2-1 ► PCI Express Root Port 1/2/3

InsydeH20 Setup Utility		Rev. 5.0
Advanced		
PCI Express Root Port 1		Control the PCI Express Root Port.
PCE Express Root Port 1	<Enable>	
PCIE Port 1 Speed	<Gen1>	
PCIE Port 1 Option ROM	<Disabled>	
F1 Help	↑ ↓ Select	F5/F6 Change Values
Esc Exit	← Select Menu	Enter Select ► SubMenu
		F9 Setup Defaults
		F10 Save and Exit

Control the PCI Express Root Port.

The optional settings are: Enabled(default), Disabled.

Select PCI Express port speed.

The optional settings are: Gen1(default), Gen2

Select PCIE TXE ROM support

The optional settings are: Disabled(default), Enabled

4-6-3 USB Configuration

InsydeH20 Setup Utility		Rev. 5.0
Advanced		
USB Configuration		Control the PCI Express Root Port.
xHCI Mode	<Best Auto>	
XHCI Controller	<Enabled>	
EHCI Controller	<Enabled>	
F1 Help	↑ ↓ Select	F5/F6 Change Values
Esc Exit	← Select Menu	Enter Select ► SubMenu
		F9 Setup Defaults
		F10 Save and Exit

XHCI Mode

Mode of operation of xHCI controller.

The optional settings are: Best Auto(default), Enabled, Disabled.

4-6-4 Video Configuration

InsydeH20 Setup Utility		Rev. 5.0
Advanced		
Vedio Configuration		Select Hardware CRT Configuration.
Configure CRT as	<CRT>	
Configure DDI0 as	<HDMI>	
Configure DDI1 as	<Mini HDMI>	
Aperture Size	<256MB>	
IGD – DVMT Pre-Allocated	<64M>	
IGD – DVMT Total Gfx Mem	<256M>	

F1 Help	↑ ↓ Select	F5/F6 Change Values	F9 Setup Defaults
Esc Exit	← Select Menu	Enter Select ►SubMenu	F10 Save and Exit

Configure CRT as

Enable or disable CRT function.

The optional settings are: CRT(default) or Default

Configure DDI0 as

Enable or disable HDMI function.

The optional settings are: HDMI(default) or disabled.

Configure DDI1 as

Enable or disable Mini HDMI function.

The optional settings are: Mini HDMI(default) or disabled.

Aperture Size

The optional settings are: 128MB, 256MB(default), 512MB.

IGD - DVMT Pre-Allocated

Use this item to select DVMT 5.0 pre-allocated (fixed) graphics memory size used by the internal graphics device.

The optional settings are: 64(default)/96/128/160/192/224/256/288/320/352/384/416/448/480/512MB

IGD - DVMT Total Gfx Mem

Use this item to select DVMT 5.0 total graphics memory size used by the internal graphics device

The optional settings are:128M, 256M(default), MAX

4-6-5 Thermal Configuration

InsydeH20 Setup Utility		Rev. 5.0	
Advanced			
Thermal Configuration Parameters		This value controls the temperature of The ACPI Critical Trip Point – the point in Which the OS will Shut the system off. NOTE: 100C is the Plan of Record (POR) For all Intel mobile procesors.	
Critical Trip Point	<110 °C>		
Passive Trip Point	<105 °C>		
F1 Help	↑ ↓ Select	F5/F6 Change Values	F9 Setup Defaults
Esc Exit	← Select Menu	Enter Select ► SubMenu	F10 Save and Exit

Thermal Configuration Parameters

This Value controls the temperature of the ACPI Critical Trip Point, the point in which the OS will shutdown the system.

Critical Trip point is the shutdown temperature, the default value is 110°

The CPU frequency will auto reduce when cpu temperature arrived to passive Trip point.

The default of the passive trip point is 105°

4-6-6 SATA Configuration

InsydeH20 Setup Utility		Rev. 5.0
Advanced		
SATA Configuration		DISABLED: Disables SATA Controller.
SATA Controller	<Enabled>	ENABLED: Enables SATA Controller.
Chipset SATA Mode	<IDE>	
SATA Speed	<Gen 1>	
IDE Mode	<Native IDE>	
SATA Port 0 Connected to an ODD		<Enabled>
SATA Port 1 Connected to an ODD		<Enabled>
▶ Serial ATA Port 0		[Not Installed]
▶ Serial ATA Port 1		[Not Installed]

F1 Help ↑ ↓ Select F5/F6 Change Values F9 Setup Defaults
Esc Exit ← Select Menu Enter Select ▶ SubMenu F10 Save and Exit

SATA Controller

Use this item to Enable or Disable SATA Device.

The optional settings are: Enabled(default) or Disabled

Chipset SATA Mode

Determine how SATA controller(s) operate.

The optional settings are: IDE Mode(default), AHCI Mode.

SATA Speed

Indicates the maximum speed the SATA controller can support.

The optional settings: Gen1, Gen2(default).

IDE Mode

Legacy IDE or Native IDE MODE,

The optional settings: Legacy IDE or Native IDE(default)

SATA Port 0 Connected to an ODD

Use this item to Enable or Disable SATA Port0 ODD function
The optional settings are: Enabled(default) or Disable

SATA Port 1 Connected to an ODD

Use this item to Enable or Disable SATA Port1 ODD function
The optional settings are: Enabled(default) or Disable

4-6-7 ACPI Table/Features Control

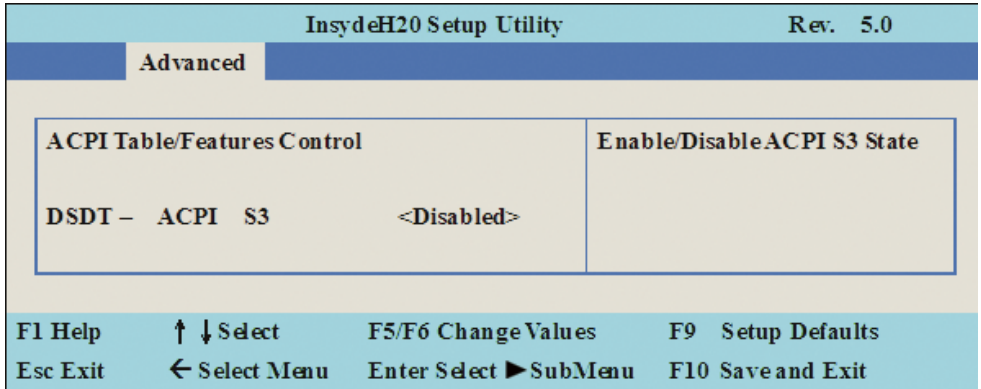

ACPI Table/Features Control

Select ACPI sleep state the system will enter when the SUSPEND button is pressed.
The optional settings: DSDT - ACPI S3 (Suspend to RAM), Enabled or Disabled(default)

4-7 Security

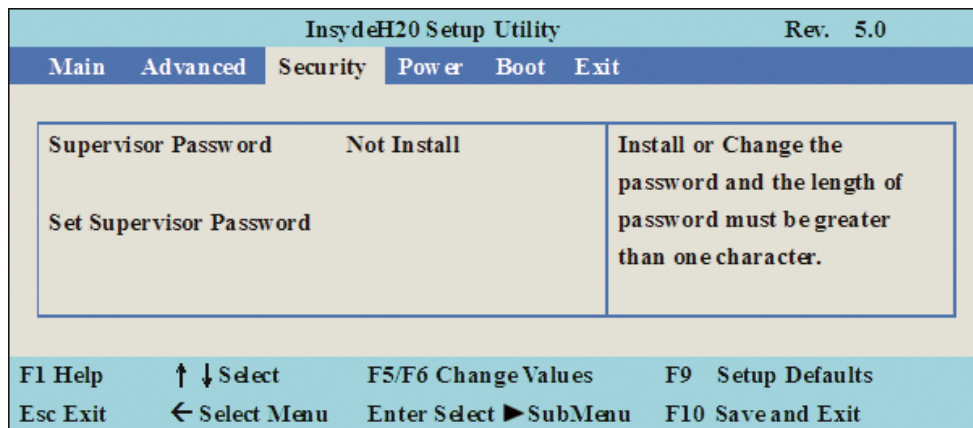

Supervisor Password

To set up an Supervisor password

1. Select Supervisor Password.

The screen then pops up an Create New Password dialog.

2. Enter your desired password that is no less than 3 characters and no more than 10 characters.
3. Hit [Enter] key to submit.

4-8 Power

InsydeH20 Setup Utility				Rev. 5.0	
Main	Advanced	Security	Power	Boot	Exit
Wake on PME		<Disabled>		Determines the action take when the system power is off and a PCI Power Management Enable wake up event occurs.	
Power Button		<Instant OFF>			
F1 Help	↑ ↓ Select	F5/F6 Change Values	F9 Setup Defaults		
Esc Exit	← Select Menu	Enter Select ► SubMenu	F10 Save and Exit		

Wake on PME

Determines the action taken when the system power is off and the PCI power management Enable wake up event occurs.

The optional settings: Enabled, Disabled(default)

Power Button

Instant OFF(default) : The system will be turn off directly when push the power button.

Delay 4 sec : The system will be turn off when push the power button for 4 sec.

4-9 Boot

InsydeH20 Setup Utility		Rev. 5.0			
Main	Advanced	Security	Power	Boot	Exit
Boot Type	<Dual Boot Type>	Select boot type to Dual type, Legacy type or UEFI type.			
Quiet Boot	<Enabled>				
EFI/Legacy Device Order	<Legacy device first>				
▶EFI					
▶Legacy					
F1 Help	↑ ↓ Select	F5/F6 Change Values	F9 Setup Defaults		
Esc Exit	← Select Menu	Enter Select ▶ SubMenu	F10 Save and Exit		

Boot type

Select boot type for Dual type ,Legacy boot type or UEFI boot type, default is Dual boot type

Quiet Boot

The optional settings are: Enabled(default), Disabled.

EFI / Legacy Device order

Determine EFI device first or legacy device first.

The optional settings: EFI device first, Legacy device first(default), smart mode

4-9-1 Legacy

InsydeH20 Setup Utility		Rev. 5.0	
Boot			
Boot Device Priority		Select Normal Boot Option Priority or Advance Boot Option Priority.	
Normal Boot Menu	<Normal>		
▶ Boot Type Order			
▶ USB			
F1 Help	↑ ↓ Select	F5/F6 Change Values	F9 Setup Defaults
Esc Exit	← Select Menu	Enter Select ▶ SubMenu	F10 Save and Exit

Normal Boot Menu

Select Normal Boot option priority or Advance Boot option priority.

The optional settings: Normal(default), Advance

4-9-2 Boot Type Order

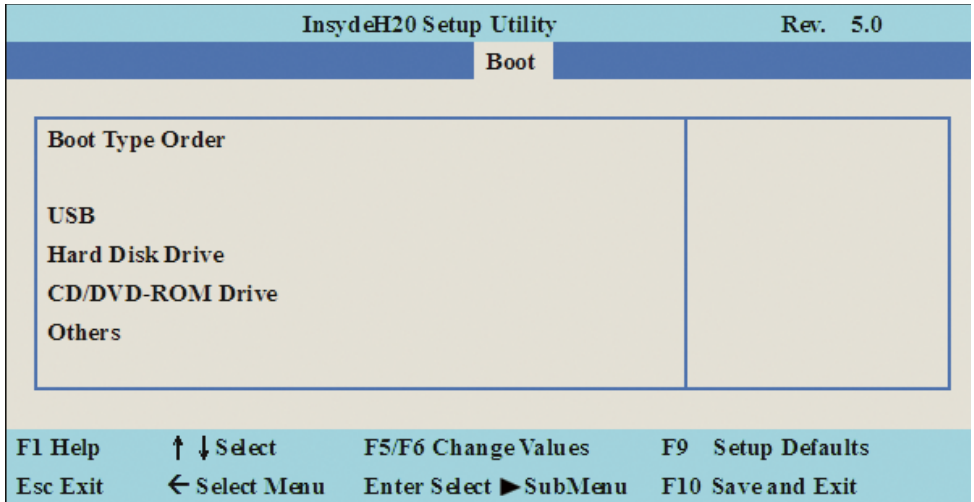

Boot Type Order

Setting the boot type priority.

The default settings is 1.USB drive 2.Hard Disk Drive 3.CD/DVD ROM drive 4.Others

4-10 EXIT

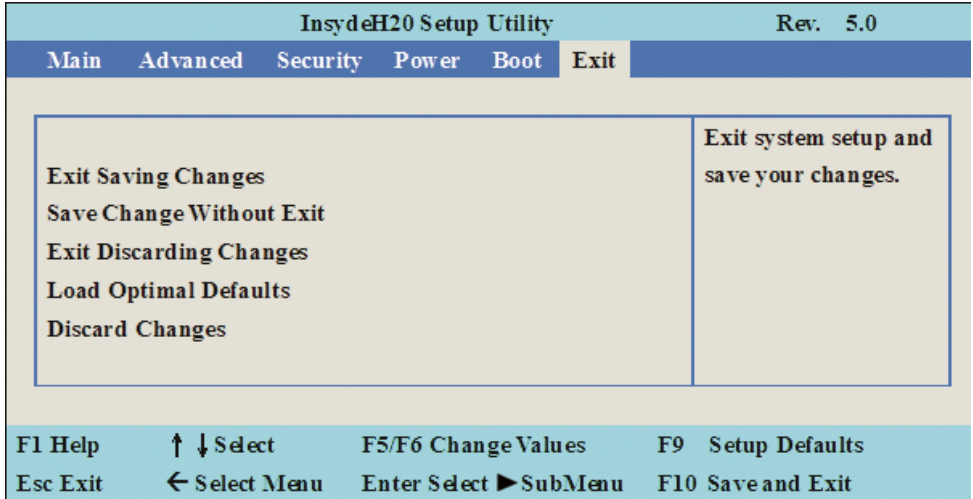

Exit Saving Changes

This item allows user to reset the system after saving the changes.

Save Change Without Exit

This item allows user to saving the changes but doesn't restart.

Exit Discard Changes

This item allows user restart the system but no saving the changes

Load Optimal Default

Use this item to restore the optimal default for all the setup options.

Discard Changes

Use this item to cancel all the setup options.

4-11 Device Manager

Please press the key F10 when boot up to go into the Device Manager menu

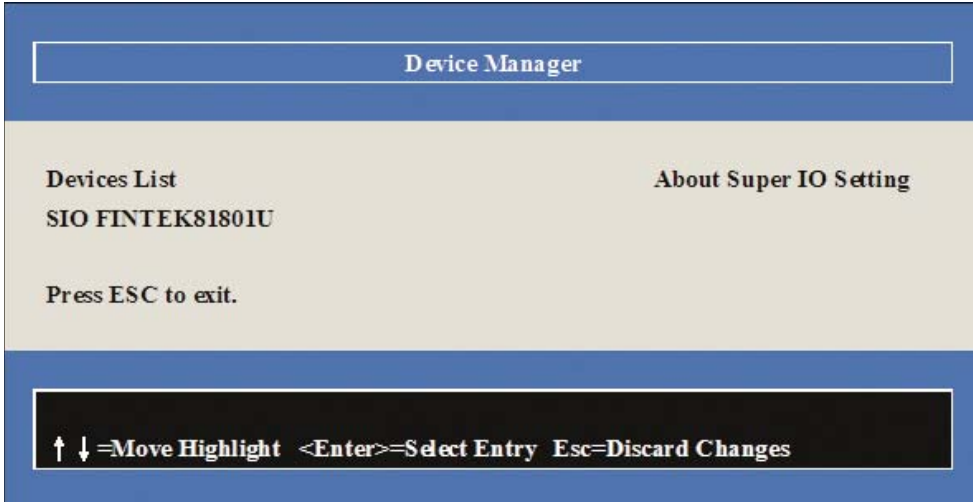

4-11-1 SIO FINTEK81801U

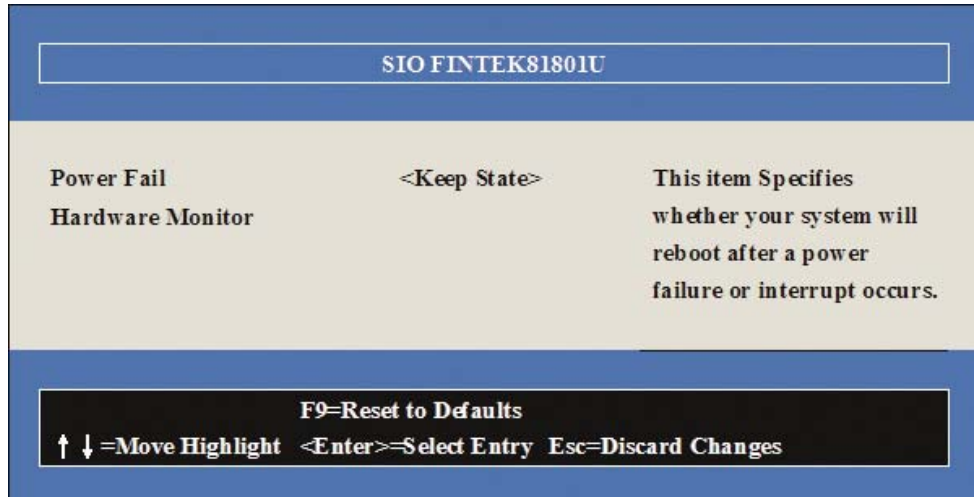

Power Failure

This item specifies whether your system will reboot after a power failure or interrupt occurs.

[Keep state] Restores the system to the status before power failure or interrupt occurred. (default)

[Always on] Leaves the computer in the power on state.

[Always off] Leaves the computer in the power off state.

4-11-2 Hardware Monitor

Hardware Monitor

Hardware Monitor

Voltage

VCC3	3.376 V
VCORE	0.888 V
VGFX	0.856 V

Temperature

CPU (°C/°F)	52°C/125°F
System (°C/°F)	48°C/118°F

Press [Enter] to view PC health status.

This section shows the status of your CPU, Fan, and overall system.

This is only available when there is Hardware Monitor function onboard.

Chapter-5

DRIVER INSTALLATION

There is a system installation DVD in the package. This DVD does not only include all the drivers you need but also some other free application programs and utility programs. In addition, this DVD also includes an auto detect software telling you which hardware is installed and which driver is needed so that your system can function properly. We call this auto detect software SYSTEM INSTALL.

SYSTEM INSTALL Supports Windows 7(32bit/64bit) / Windows 8/8.1(32bit/64bit)

Insert the DVD into your DVD-ROM drive and the SYSTEM INSTALL menu should appear as below. If the menu does not appear, double-click MY COMPUTER and double-click DVD-ROM drive or click START, click RUN, and type X:\SETUP.EXE (assuming your DVD-ROM drive is X).



Make your selection from SYSTEM INSTALL menu:

1. Auto Detect Main board and OS to AUTOMATIC DRIVER INSTALLATION menu
2. Browse DVD to view the contents of the DVD
3. Exit to exit SYSTEM INSTALL menu

Bay Trail for Windows 8.1 (x64)

1. INF

4. LAN

2. VGA

5. TXE

3. HD Audio

6. MBI

Back to previous page

Bay Trail for Windows 7 (x64)

- | | |
|--------------|--------------|
| 1. INF | 5. HD Audio |
| 2. VGA | 6. LAN |
| 3. Serial IO | 7. TXE Patch |
| 4. xHCI | 8. TXE |

[Back to previous page](#)

1. INF Install Intel Baytrail chipset driver
2. VGA Install onboard VGA driver
3. Serial IO Install Serial IO driver (FOR Win 7 only)
4. xHCI Install Intel USB 3.0 xHCI driver (FOR Win 7 only)
5. HD Audio Install HD Audio Codec driver
6. MBI Install MBI driver (FOR Win 8/8.1 only)
7. LAN To the LAN driver Readme file
8. TXE Patch Install Intel TXE patch (FOR Win 7 only)
9. TXE Install Intel TXE driver

Each selection is illustrated below:

5-1 INF Install Intel Baytrail Chipset Driver (example for WIN8 64bit)



1. At the "AUTOMATIC DRIVER INSTALLATION menu" screen, click "INF".



2. At the "Intel® Chipset Device Software" screen, click "Next".



3. At the "License Agreement" screen, click "Yes".

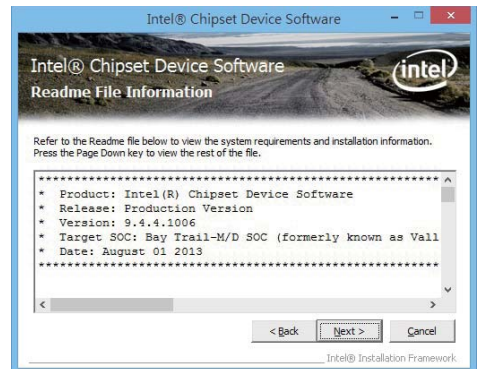

4. At the "Readme File Information" screen, Click "Next".

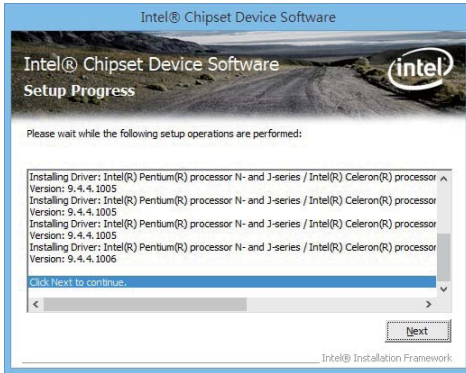

5. Click "Next"



6. Click "Finish" & restart computer.

NOTE: SYSTEM INSTALL will auto detect file path

For Windows 7 64/32-bit,

X:\driver\INTEL\BAY\INF\WIN7\infinst_autol.exe

For Windows 8 / 8.1 32/64-bit

X:\driver\INTEL\BAY\INF\WIN_8_64\infinst_autol.exe

5-2 VGA Install Intel Baytrail VGA Driver (example for WIN8 64bit)

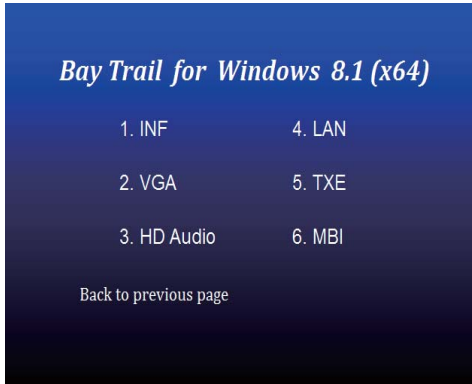

1. At the "AUTOMATIC DRIVER INSTALLATION menu" screen, click "VGA".

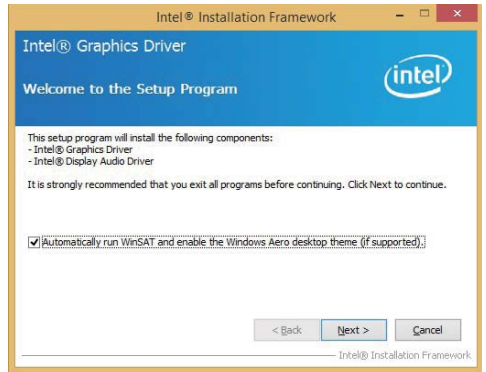

2. At the "Welcome to the Setup Program screen, Click "Next".

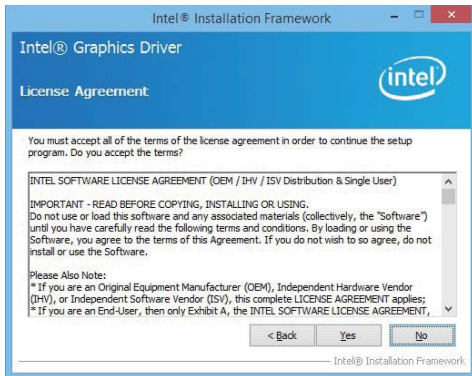

3. At the "License Agreement" screen, Click "Yes"

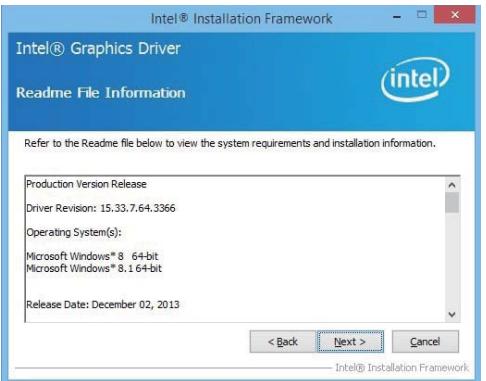

4. At the "Readme File Information" screen, Click "Next"

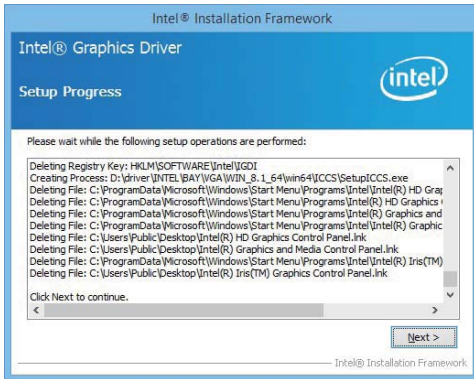

5. At the "Setup Progress" screen,
Click "Next".

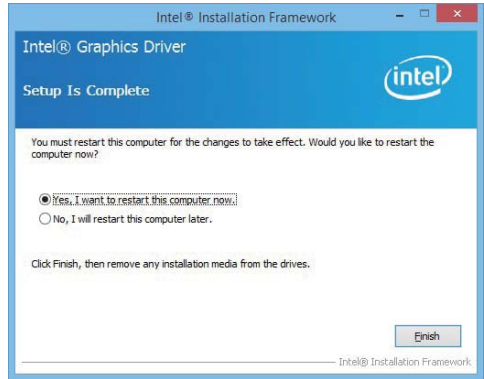

6. Click "Finish" to restart computer

NOTE: SYSTEM INSTALL will auto detect file path

For Windows 7 32-bit,

X:\driver\INTEL\BAY\VGA\WIN_7_32\Setup.exe

For Windows 7 64-bit

X:\driver\INTEL\BAY\VGA\WIN_7_64\Setup.exe

For Windows 8 / Windows 8.1 32-bit

X:\driver\INTEL\BAY\VGA\WIN_8_32\Setup.exe

For Windows 8 / Windows 8.1 64-bit

X:\driver\INTEL\BAY\VGA\WIN_8_64\Setup.exe

5-3 Serial IO Install Driver Baytrail Serial IO Driver (FOR Windows 7 only)



1. At the "AUTOMATIC DRIVER INSTALLATION menu" screen, click "Serial IO".



2. At the "Welcome to the Setup Programs screen, Click "Next".



3. At the "License Agreement" screen, Click "Yes"

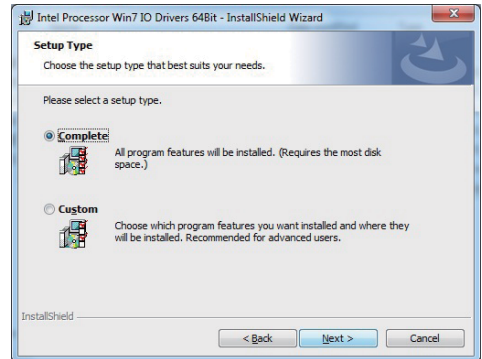

4. At the "Setup type" screen, select "complete" and Click "Next".

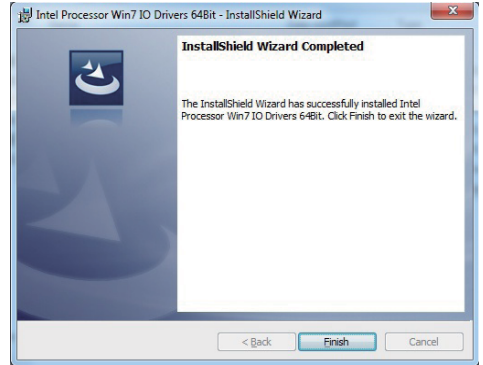
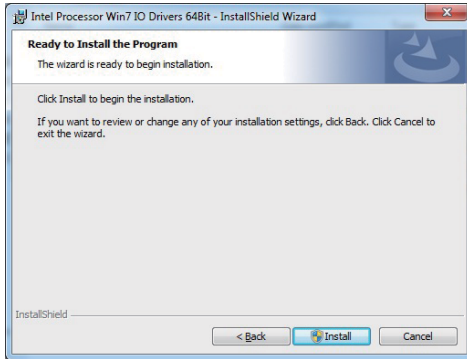

5. At the "Ready to install the program" screen, Click "Install"
6. Click "Finish" and restart computer

NOTE: SYSTEM INSTALL will auto detect file path
For Windows 7 32-bit,
X:\driver\INTEL\BAY\SERIALIO\WIN7_32Bit.msi
For Windows 7 64-bit
X:\driver\INTEL\BAY\SERIALIO\Win7_64Bit.msi

5-4 xHCI Install Intel USB 3.0 xHCI Driver (FOR Windows 7 only)



1. At the "AUTOMATIC DRIVER INSTALLATION menu" screen, click "xHCI".

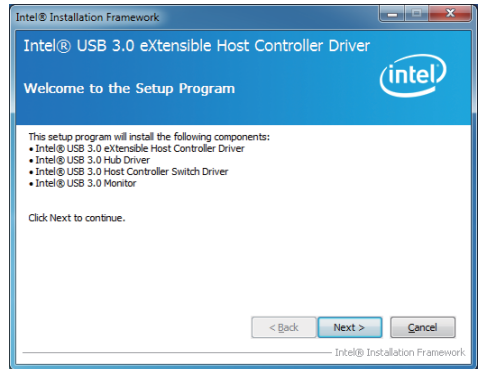

2. At the "Welcome to the Setup Program screen, Click "Next".

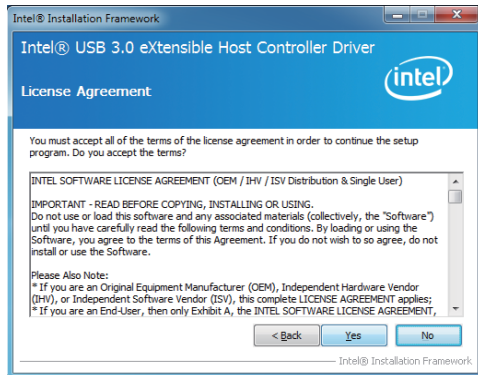

3. At the "License Agreement" screen, Click "Yes".



4. At the "Readme File Information" screen, Click "Next".

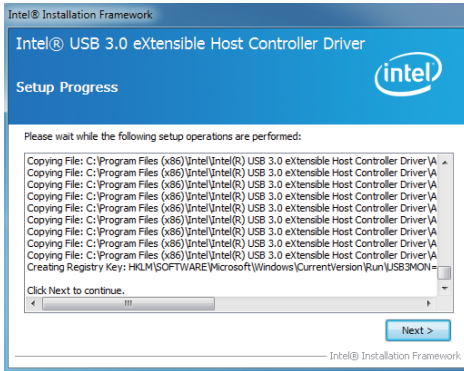

5. At the "Setup Progress" screen, Click "Next". 6. Click "Finish" to restart computer

NOTE: SYSTEM INSTALL will auto detect file path

For Windows 7 32 / 64-bit,

X:\driver\INTEL\BAY\XHC\Driver_Installer\Setup.exe

5-5 HD Audio Install High Definition Audio Driver (example for WIN8 64bit)

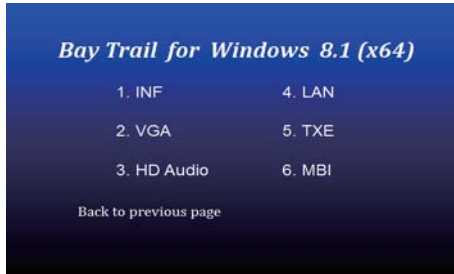

1. At the "AUTOMATIC DRIVER INSTALLATION" menu, click "HD Audio"

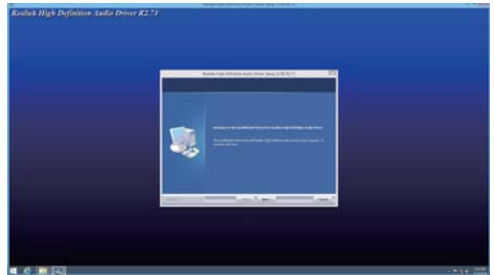

2. Click "Next".

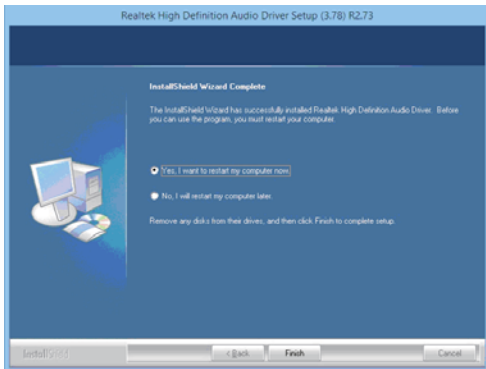

3. Click "Finish" to restart computer

NOTE: SYSTEM INSTALL will auto detect file path
For Windows 7 32 / 64-bit, Windows 8/8.1 32 / 64-bit
X:\driver\INTEL\BAY\SOUND\Win7_Win8_Win81_R273.exe

5-6 MBI Install Intel MBI Driver (FOR Win 8/8.1 only)

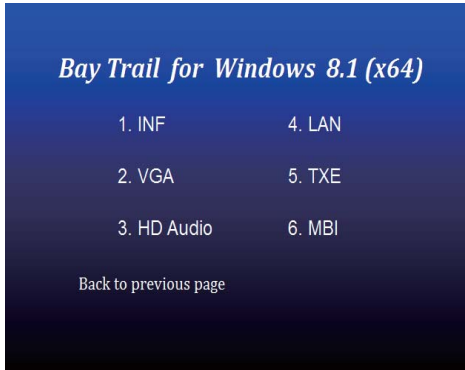

1. At the "AUTOMATIC DRIVER INSTALLATION menu", click "HD Audio"

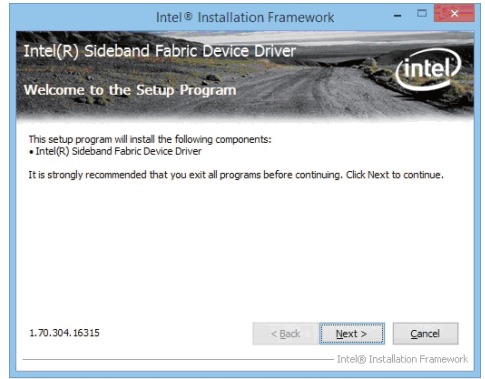

2. At the "Welcome to the Setup Program screen, Click "Next".



3. At the "License Agreement" screen, Click "Yes".

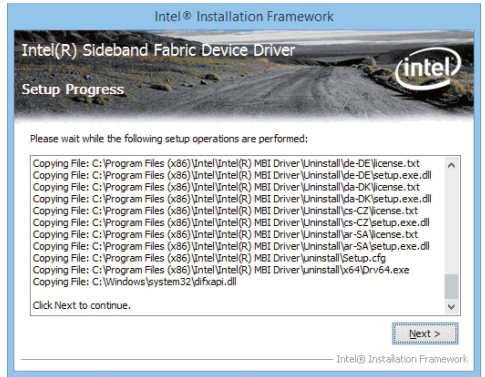

4. At the "Setup Progress" screen, Click "Next".

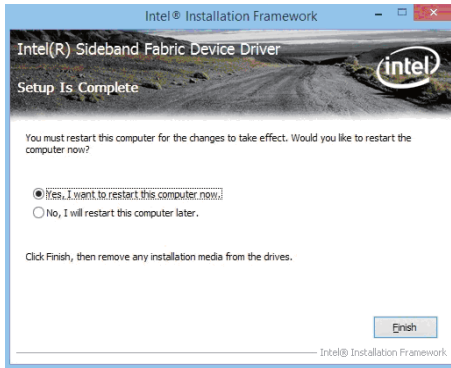

5. Click "Finish" to restart computer

NOTE: SYSTEM INSTALL will auto detect file path

For Windows 8/8.1 32 / 64-bit,

X:\driver\INTEL\BAY\MBI\Setup.exe

5-7 TXE Install Intel TXE driver

5-7-1 TXE Install for WIN8/WIN8.1

Bay Trail for Windows 8.1 (x64)

1. INF	4. LAN
2. VGA	5. TXE
3. HD Audio	6. MBI

Back to previous page

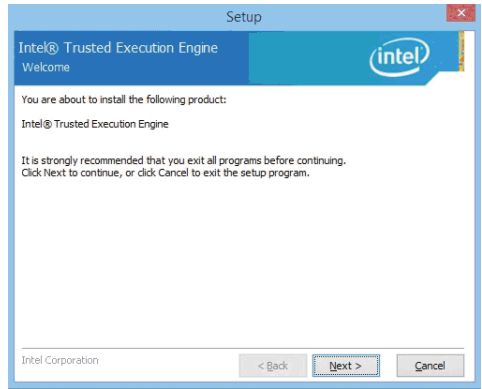

1. At the "AUTOMATIC DRIVER INSTALLATION menu", click "TXE"
2. At the "Setup" screen, Click "Next".

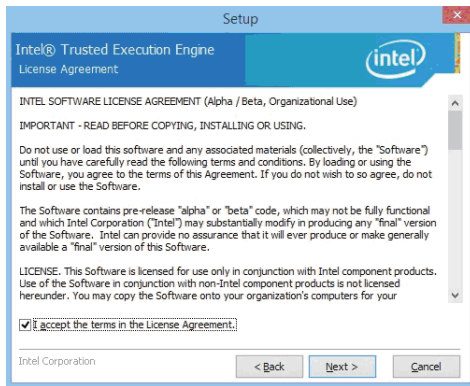

3. At the "License Agreement" screen, Click "Yes".

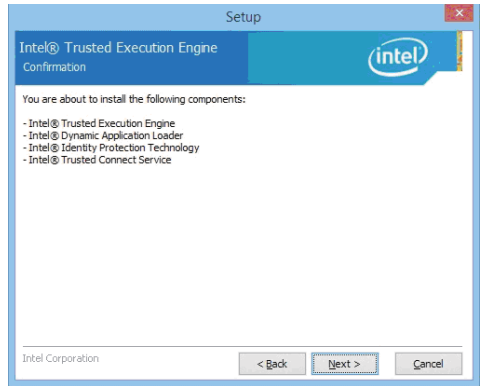

4. Click "Next".

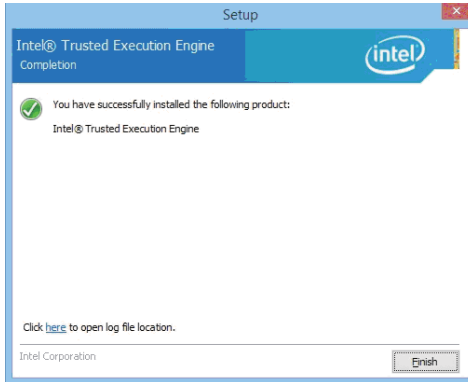

5. Click "Finish" & restart computer

NOTE: SYSTEM INSTALL will auto detect file path

For Windows 8 32 / 64-bit,

X:\driver\INTEL\BAY\TXE\WIN_8\SetupTXE.exe

For Windows 8.1 32 / 64-bit,

X:\driver\INTEL\BAY\TXE\WIN_8.1\SetupTXE.exe

5-7-2 TXE Install for WIN7

Please install PXE Patch first.



1. At the "AUTOMATIC DRIVER INSTALLATION menu", click "TXE Patch "

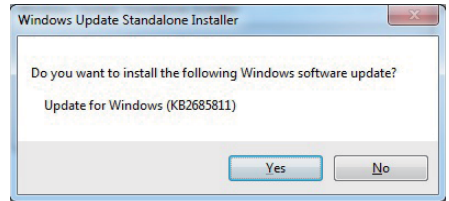

2. At the "Windows Update" screen, Click "Yes".

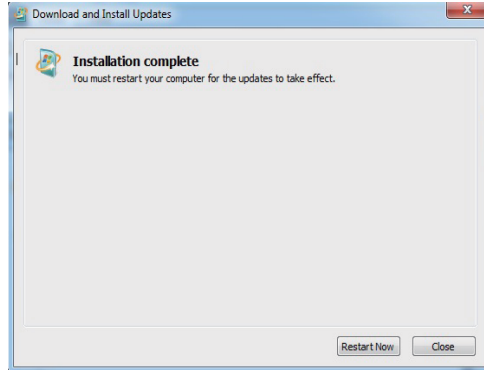

3. Click "Finish" & restart computer



4. At the "AUTOMATIC DRIVER INSTALLATION menu", click "TXE "

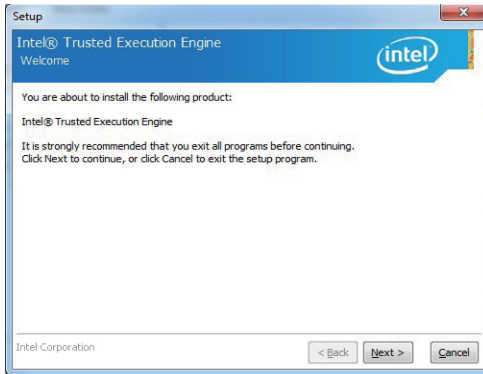

5. At the "TXE Setup" screen, Click "Next".

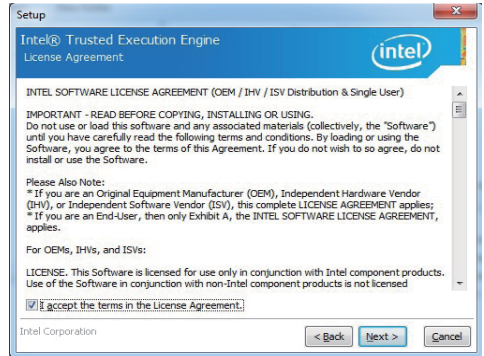

6. At the "License Agreement" screen, Click "Yes".

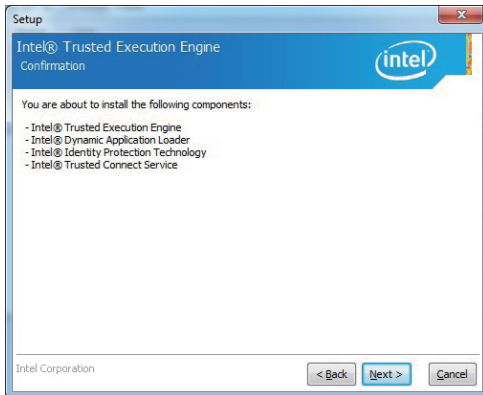

7. Click "Next".

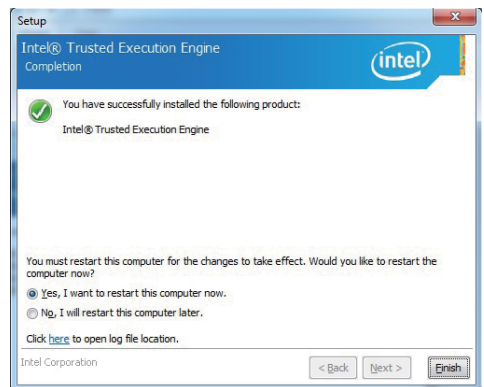

8. Click "Finish" & restart computer

NOTE: SYSTEM INSTALL will auto detect file path

For Windows 7 32 / 64-bit,

TXE Patch

X:\driver\INTEL\BAY\TXE\WIN_7\kmdf-1.11-Win-6.1-x86.msu

X:\driver\INTEL\BAY\TXE\WIN_7\kmdf-1.11-Win-6.1-x64.msu

TXE

X:\driver\INTEL\BAY\TXE\WIN_7\SetupTXE.exe

X:\driver\INTEL\BAY\TXE\WIN_7\SetupTXE.exe

5-8 How to update Insyde BIOS

Under DOS Mode

STEP 1. Prepare a bootable disc.

(Storage device could be USB FDD or USB pen drive.)

STEP 2. Copy utility program to your bootable disc. You may download it from our website.

STEP 3. Copy the latest BIOS for your LEX motherboard from our website to your bootable disc.

STEP 4. (Here take 2I385S as an example, please enter your motherboard's name)

Insert your bootable disc into X: (X could be C:, A: or others.

It depends on which type of storage device you use.)

Start the computer and type

```
X:\: H2OFFT-D.EXE 2I385SD2.BIN -BIOS -ALL
```

2I385SD2.BIN is the file name of the latest BIOS.

It may be 2I385SD1.BIN or 2I385SD2.BIN, etc.

Please leave one space between .ROM & -BIOS -ALL

By Bay Trail series mainboard, please type

```
X:\: H2OFFT-D.EXE 2I385SD2.BIN -BIOS -ALL
```

```
-BIOS : Flash BIOS region
```

```
-ALL : Flash all
```

STEP 5. Press ENTER and the BIOS will be updated,

Computer will restart automatically.

Appendix A: Power Consumption Test

Condition

Item	Spec
CPU	Celeron J1900 2 Ghz
Memory	DDR3L 1333 2GB
Operating System	Windows 7 / SP1
Test Program	3D Mark 06
HDD 2.5" SATA	Slim Type HDD
mSATA	32GB

Test Result for reference only !

Storage	Power off	Start up		Operation Maximum	Shut down Maximum	In Put Voltage
		Maximum	Stable			
Slim Type HDD	0.12A	0.8A	0.51A	1.31A	0.71A	12V
	0.07A	0.43A	0.32A	0.62A	0.37A	24V
mSATA	0.12A	0.8A	0.45A	1.09A	0.65A	12V
	0.07A	0.41A	0.24A	0.56A	0.34A	24V

The power consumption depends on your device choice!

Appendix B: Resolution list

640 x 480 x (256 / 16bit / 32bit)
800 x 600 x (256 / 16bit / 32bit)
1024 x 768 x (256 / 16bit / 32bit)
1152 x 864 x (256 / 16bit / 32bit)
1280 x 600 x (256 / 16bit / 32bit)
1280 x 720 x (256 / 16bit / 32bit)
1280 x 768 x (256 / 16bit / 32bit)
1280 x 800 x (256 / 16bit / 32bit)
1280 x 960 x (256 / 16bit / 32bit)
1280 x 1024 x (256 / 16bit / 32bit)
1400 x 1050 x (256 / 16bit / 32bit)
1440 x 900 x (256 / 16bit / 32bit)
1600 x 900 x (256 / 16bit / 32bit)
1600 x 1200 x (256 / 16bit / 32bit)
1680 x 1050 x (256 / 16bit / 32bit)
1920 x 1080 x (256 / 16bit / 32bit)
1920 x 1200 x (256 / 16bit / 32bit)

Appendix C: F75111N I²C DIO device

1-1 IO Device:F75111 under DOS

The Sample code source you can download from

Source file: F75111_Dos_Src.rar http://tprd.info/lexwiki/index.php/IO_Device:F75111_under_DOS

Binary file: F75111_Dos_Bin.rar

USERNAME & PASSWORD: sf

How to use this Demo Application

- 1.Boot Ms-Dos Operating System
- 2.execute "75WDT.EXE" binary file
- 3.Input 1 to Enable WDT timer or input 0 to Disable it.
- 4.input numbers of second for chip countdown and Reset Computer

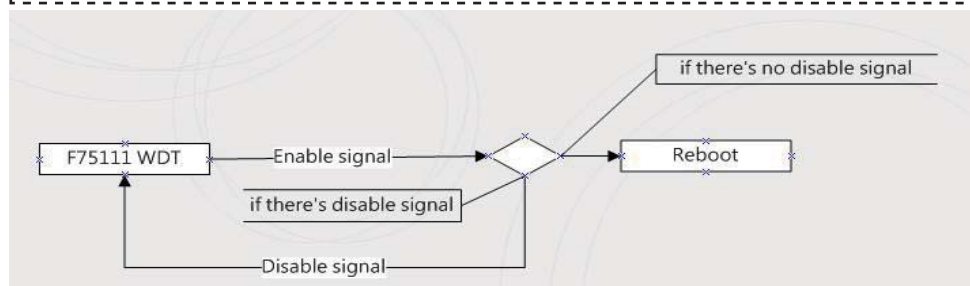

Introduction

How to use this Demo Application

```
WriteI2CByte(I2CADDR, CONFIG, 0x03);//Set Watch Dog Timer function
WriteI2CByte(I2CADDR, WDT_TIMER, timer);//Set Watch Dog Timer range from 0-255.
WriteI2CByte(I2CADDR, WDT_TIMER_CTL, 0x73);//Enable Watch Dog Timer in second and pulse mode
```

How to use this Demo Application

```
WriteI2CByte(I2CADDR, WDT_TIMER_CTL, 0x00);
```

How to use this Demo Application

```
void pause(int time)
{
    asm mov ah,0h; //Ah = 00 Read System Time Counter
    asm int 1ah; //read time from Time Counter and store it in DX register
    asm add dx,time;
    asm mov bx,dx;
    label:
    asm int 1ah;
    asm cmp bx,dx;
    asm jne label;
}
```

1-2 IO Device: F75111 under Windows

The Sample code source you can download from



Source file: F75111_DIOSrc.rar http://tprd.info/lexwiki/index.php/IO_Device:F75111

Binary file: F75111_DemoBin.rar

USERNAME & PASSWORD: sf

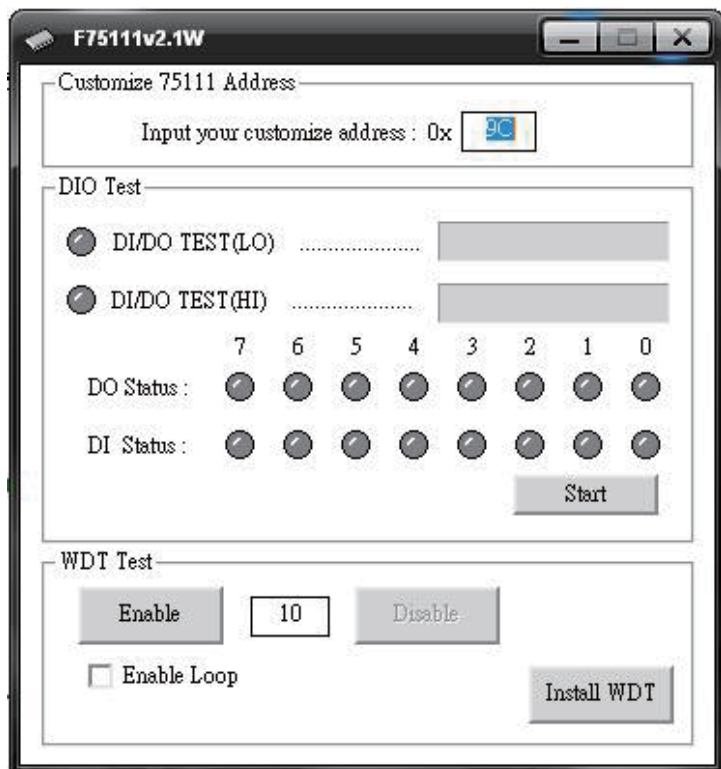
How to use this Demo Application



1. Press the "Start" button to test DIO function
2. Press the "Enable" button to test WDT function
3. Press the "Disable" button to disable WDT
4. Check the "Enable Loop" box and press "Enable" to do WDT loop test
5. Press "Install WDT" to set the system to autorun this application when booting, press again to remove this application when booting.
6. If WDT enable, system icon will be . if disable, system icon will be 

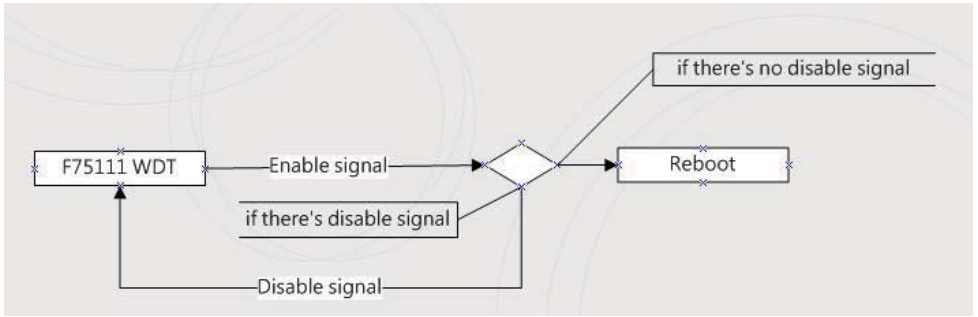

p.s.
 f75111 send "F75111_SetWDTEnable(BYTE byteTimer)" including a parameter "timer",
 if there's no disable signal (F75111_SetWDTDisable()) to stop it before timer countdown to 0, System will reboot.
 if there's disable signal received, resent Enable WDT signal, for a loop to prevent from reboot

Introduction

Initial Internal F75111 port address (0x9c)

```

define GPIO1X, GPIO2X, GPIO3X to input or output
and Enable WDT function pin
  
```

Set F75111 DI/DO (sample code as below Get Input value/Set output value)

```

DO: InterDigitalOutput(BYTE byteValue)
DI: InterDigitalInput()
  
```

Enable/Disable WDT

```

Enable : F75111_SetWDTEnable (BYTE byteTimer)
Disable: F75111_SetWDTDisable ()
  
```

PULSE mode

Sample to setting GP33, 32, 31, 30 output 1mS low pulse signal.

```

{
this->Write_Byte(F75111_INTERNAL_ADDR, GPIO3X_PULSE_CONTROL,      0x00); //This is setting low pulse output
this->Write_Byte(F75111_INTERNAL_ADDR, GPIO3X_PULSE_WIDTH_CONTROL, 0x01); //This selects the pulse width to 1mS
this->Write_Byte(F75111_INTERNAL_ADDR, GPIO3X_CONTROL_MODE,       0x0F); //This is setting the GP33, 32, 31, 30 to output function.
this->Write_Byte(F75111_INTERNAL_ADDR, GPIO3X_Output_Data ,       0x0F); //This is setting the GP33, 32, 31, 30 output data.
}
  
```

Sample to setting GP33, 32, 31, 30 output 1mS low pulse signal.

```

void F75111::InitInternalF75111()
{
this->Write_Byte(F75111_INTERNAL_ADDR,GPIO1X_CONTROL_MODE ,0x00); //set GPIO1X to Input function
this->Write_Byte(F75111_INTERNAL_ADDR,GPIO3X_CONTROL_MODE ,0x00); //set GPIO3X to Input function
this->Write_Byte(F75111_INTERNAL_ADDR,GPIO2X_CONTROL_MODE ,0xFF); //set GPIO2X to Output function

this->Write_Byte(F75111_INTERNAL_ADDR,F75111_CONFIGURATION ,0x03); //Enable WDT OUT function
}
  
```

Set output value

```
void F75111::InterDigitalOutput(BYTE byteValue)
{
    BYTE byteData = 0;
    byteData = (byteData & 0x01 )? byteValue + 0x01 : byteValue;
    byteData = (byteData & 0x02 )? byteValue + 0x02 : byteValue;
    byteData = (byteData & 0x04 )? byteValue + 0x04 : byteValue;
    byteData = (byteData & 0x08 )? byteValue + 0x08 : byteValue;
    byteData = (byteData & 0x10 )? byteValue + 0x10 : byteValue;
    byteData = (byteData & 0x20 )? byteValue + 0x20 : byteValue;
    byteData = (byteData & 0x40 )? byteValue + 0x40 : byteValue;
    byteData = (byteData & 0x80 )? byteValue + 0x80 : byteValue;           // get value bit by bit

    this->Write_Byte(F75111_INTERNAL_ADDR,GPIO2X_OUTPUT_DATA,byteData); // write byteData value via GPIO2X output pin
}
```

Get Input value

```
BYTE F75111::InterDigitalInput()
{
    BYTE byteGPIO1X = 0;
    BYTE byteGPIO3X = 0;
    BYTE byteData = 0;

    this->Read_Byte(F75111_INTERNAL_ADDR,GPIO1X_INPUT_DATA,&byteGPIO1X); // Get value from GPIO1X
    this->Read_Byte(F75111_INTERNAL_ADDR,GPIO3X_INPUT_DATA,&byteGPIO3X); // Get value from GPIO3X

    byteGPIO1X = byteGPIO1X & 0xF0;           // Mask unuseful value
    byteGPIO3X = byteGPIO3X & 0x0F;           // Mask unuseful value

    byteData = ( byteGPIO1X & 0x10 )? byteData + 0x01 : byteData;
    byteData = ( byteGPIO1X & 0x80 )? byteData + 0x02 : byteData;
    byteData = ( byteGPIO1X & 0x40 )? byteData + 0x04 : byteData;
    byteData = ( byteGPIO3X & 0x01 )? byteData + 0x08 : byteData;

    byteData = ( byteGPIO3X & 0x02 )? byteData + 0x10 : byteData;
    byteData = ( byteGPIO3X & 0x04 )? byteData + 0x20 : byteData;
    byteData = ( byteGPIO3X & 0x08 )? byteData + 0x40 : byteData;
    byteData = ( byteGPIO1X & 0x20 )? byteData + 0x80 : byteData;           // Get correct DI value from GPIO1X & GPIO3X

    return byteData;
}
```

Enable WatchDog

```
void F75111_SetWDTEnable (BYTE byteTimer)
{
    WriteByte(F75111_INTERNAL_ADDR,WDT_TIMER_RANGE ,byteTimer);           // set WatchDog range and timer
    WriteByte(F75111_INTERNAL_ADDR,WDT_CONFIGURATION,WDT_TIMEOUT_FLAG | WDT_ENABLE | WDT_PULSE | WDT_PSWIDTH_100MS);
                                                                           // Enable WatchDog, Setting WatchDog configure
}
```

Disable WatchDog

```
void F75111_SetWDTDisable ()  
{  
    WriteByte(F75111_INTERNAL_ADDR,WDT_CONFIGURATION,0x00); // Disable WatchDog  
}
```

1-3 IO Device: F75111 VB6 under Windows

The Sample code source you can download from

Source file: **75111_VB_v10.rar** http://tprd.info/lexwiki/index.php/IO_Device:F75111_VB6

Binary file: **75111_VB_Src.rar**

USERNAME & PASSWORD: **sf**

How to use this Demo Application

75111_DEMO VB v1.0

Please key-in the timer by sec !!

A **B**

Enable WDT Disable WDT

Please key-in the DO Value by hex !! exp:0xFF = FF

Set DO Value **C**

Push the Button will show the DI 1X_3X Value !!

D

Check DI Value 1X Value 2X Value

A Function - Enable WDT timer ,Key-in the value by seconds then system will reboot after value which you key-in in left text box !!

B Function - Disable WDT timer ,Push down the button then WDT timer value will be clear !!

C Function - Set DO Value ,Key-in the DO value by hex then push the button !!

D Function - Check DI Value ,The right side two text box will display DI 1X & 2X Value when you push down the button!!

SDK Function Introduction

Function EnableWDT

```
Function EnableWDT(timer As Integer)
```

```
Call Writel2CByte(&H3, &H3)
```

```
Call Writel2CByte(&H37, timer)
```

```
Call Writel2CByte(&H36, &H73)
```

```
End Function
```

Function DisableWDT

```
Function DisableWDT()
```

```
Call Writel2CByte(&H36, &H0)
```

```
End Function
```

Function SetDOValue

```
Function SetDOValue(dovalue As Integer)
```

```
Call Writel2CByte(&H23, &H0)
```

```
Call Writel2CByte(&H20, &HFF)
```

```
Call Writel2CByte(&H2B, &HFF)
```

```
Call Writel2CByte(&H21, dovalue)
```

```
End Function
```

Function CheckDIValue

```
Function CheckDIValue()
```

```
Dim GPIO1X As Integer
```

```
Dim GPIO3X As Integer
```

```
Dim DI1Xhex As String
```

```
Dim DI3Xhex As String
```

```
Call Readl2CByte(&H12, GPIO1X)
```

```
Call Readl2CByte(&H42, GPIO3X)
```

```
DI1Xhex = Hex(GPIO1X)
```

```
DI3Xhex = Hex(GPIO3X)
```

```
Text3.Text = "0x" + DI1Xhex
```

```
Text4.Text = "0x" + DI3Xhex
```

```
End Function
```

1-4 IO Device: F75111 under linux

The Sample code source you can download from

Source file: F75111v2.0L.tar.gz http://tprd.info/lexwiki/index.php/IO_Device:F75111_under_linux

Binary file: F75111v2.0LBin.tar.gz

USERNAME & PASSWORD: sf

How to compile source code

1. Compile source code with Code::Blocks

download and install the Code::Block with command "apt-get install codeblocks"

Open an exist project(F75111.cbp) in Code::Blocks, click the compile button

(add an option 'pkg-config --libs gtk+-2.0 gthread-2.0' in "Project->Build Option->Linker Setting->Other linker option")

2. Compile source code with "make"

1.cd F75111

1.make

1.src/f75111 // execute the binary file

How to use this Demo Application



1. Press the "Start" button to test DIO function
2. Press the "Enable" button to test WDT function
3. Press the "Disable" button to disable WDT
4. Check the "Enable Loop" box and press "Enable" to do WDT loop test
5. Press "Install" to set the system to autorun this application when booting, press "Uninstall" to remove this application when booting.
6. If WDT enable, system icon will be blinking.

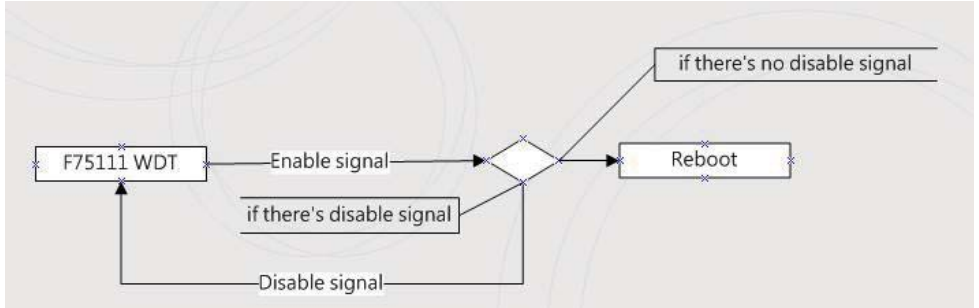

p.s.
 f75111 send "F75111_SetWDTEnable(BYTE byteTimer)" including a parameter "timer",
 if there's no disable signal (F75111_SetWDTDisable()) to stop it before timer countdown to 0, System will reboot.
 if there's disable signal received, resent Enable WDT signal, for a loop to prevent from reboot p.s.

Introduction

IO function In file SMBus.c

```

void SMBusIoWrite(BYTE byteOffset,BYTE byteData)
{
    outb( byteData , m_SMBusMapIoAddr + byteOffset);
}

BYTE SMBusIoRead(BYTE byteOffset)
{
    DWORD dwAddrVal;

    dwAddrVal = inb(m_SMBusMapIoAddr + byteOffset);
    return (BYTE)(dwAddrVal & 0xFF);
}
  
```

Initial internal F75111

```

void F75111::InitInternalF75111()
{
    this->Write_Byte(F75111_INTERNAL_ADDR,GPIO1X_CONTROL_MODE ,0x00); //set GPIO1X to Input function
    this->Write_Byte(F75111_INTERNAL_ADDR,GPIO3X_CONTROL_MODE ,0x00); //set GPIO3X to Input function
    this->Write_Byte(F75111_INTERNAL_ADDR,GPIO2X_CONTROL_MODE ,0xFF); //set GPIO2X to Output function

    this->Write_Byte(F75111_INTERNAL_ADDR,F75111_CONFIGURATION, 0x03); //Enable WDT OUT function
}
  
```

Set output value

```
void F75111::InterDigitalOutput(BYTE byteValue)
{
    BYTE byteData = 0;
    byteData = (byteData & 0x01 )? byteValue + 0x01 : byteValue;
    byteData = (byteData & 0x02 )? byteValue + 0x02 : byteValue;
    byteData = (byteData & 0x04 )? byteValue + 0x04 : byteValue;
    byteData = (byteData & 0x80 )? byteValue + 0x08 : byteValue;
    byteData = (byteData & 0x40 )? byteValue + 0x10 : byteValue;
    byteData = (byteData & 0x20 )? byteValue + 0x20 : byteValue;
    byteData = (byteData & 0x10 )? byteValue + 0x40 : byteValue;
    byteData = (byteData & 0x08 )? byteValue + 0x80 : byteValue;           // get value bit by bit

    this->Write_Byte(F75111_INTERNAL_ADDR,GPIO2X_OUTPUT_DATA,byteData); // write byteData value via GPIO2X output pin
}
```

Get Input value

```
BYTE F75111::InterDigitalInput()
{
    BYTE byteGPIO1X = 0;
    BYTE byteGPIO3X = 0;
    BYTE byteData = 0;

    this->Read_Byte(F75111_INTERNAL_ADDR,GPIO1X_INPUT_DATA,&byteGPIO1X); // Get value from GPIO1X
    this->Read_Byte(F75111_INTERNAL_ADDR,GPIO3X_INPUT_DATA,&byteGPIO3X); // Get value from GPIO3X

    byteGPIO1X = byteGPIO1X & 0xF0;           // Mask unuseful value
    byteGPIO3X = byteGPIO3X & 0x0F;           // Mask unuseful value

    byteData = ( byteGPIO1X & 0x10 )? byteData + 0x01 : byteData;
    byteData = ( byteGPIO1X & 0x80 )? byteData + 0x02 : byteData;
    byteData = ( byteGPIO1X & 0x40 )? byteData + 0x04 : byteData;
    byteData = ( byteGPIO3X & 0x01 )? byteData + 0x08 : byteData;

    byteData = ( byteGPIO3X & 0x02 )? byteData + 0x10 : byteData;
    byteData = ( byteGPIO3X & 0x04 )? byteData + 0x20 : byteData;
    byteData = ( byteGPIO3X & 0x08 )? byteData + 0x40 : byteData;
    byteData = ( byteGPIO1X & 0x20 )? byteData + 0x80 : byteData;           // Get correct DI value from GPIO1X & GPIO3X

    return byteData;
}
```

Enable WatchDog

```
void F75111_SetWDTEnable (BYTE byteTimer)
{
    WriteByte(F75111_INTERNAL_ADDR,WDT_TIMER_RANGE ,byteTimer);           // set WatchDog range and timer
    WriteByte(F75111_INTERNAL_ADDR,WDT_CONFIGURATION,WDT_TIMEOUT_FLAG | WDT_ENABLE | WDT_PULSE | WDT_PSWIDTH_100MS);
                                                                           // Enable WatchDog, Setting WatchDog configure
}
```

Disable WatchDog

```
void F75111_SetWDTDisable ()
{
    WriteByte(F75111_INTERNAL_ADDR,WDT_CONFIGURATION,0x00);           // Disable WatchDog
}
```